

Hearth Venting Manual

Mechanical Venting of Fireplaces



ENERVEX[®]
VENTING DESIGN SOLUTIONS



Published by
ENERVEX Inc.
1685 Bluegrass Lakes Pkwy.
Alpharetta, GA 30022

First Edition - 2005
Second Edition - 2007
Third Edition - 2009
Fourth Edition - 2011
Fifth Edition - 2014

Hearth Venting Manual, Fifth Edition

Copyright © 2014, 2011, 2009, 2007, 2005 by ENERVEX Inc., Alpharetta, Georgia 30004.

All rights reserved. No part of this book may be reproduced, in any form or by any means, without permission in writing from the publisher.

Requests for permission should be made to ENERVEX Inc. at the address listed above.

Printed and bound in the United States of America.
Date of Impression: June 2014

ENERVEX Inc. disclaims all warranties, either expressed or implied, including, but not limited to, implied warranties or merchantability and fitness for a particular purpose, with respect to the instructions contained in this manual.

In no event shall ENERVEX Inc. be liable for any damages whatsoever, including, without limitation, damages for loss of business profits, business interruption, loss of business information, or pecuniary loss, even if ENERVEX Inc. has been advised of the possibility of such damages. Because some states do not limit the exclusion or limitation of liability for consequential or incidental damages, the above limitations may not apply to you.

Information and specifications in this manual is subject to change without notice.

Table of Contents



INTRODUCTION	2
1. VENTING IN GENERAL	3
1.1 Designing Venting Systems	3
1.2 Gravity vs. Mechanical Venting	3
2. VENTING PROBLEMS AND POSSIBLE SOLUTIONS	4
2.1 Chimney Performance Problems	4
2.1.1 Problems associated with the venting system	5
2.1.2 Problems associated with the heating appliance	7
2.1.3 Problems associated with the building/house	9
2.1.4 Problems associated with the building's environment	11
3. VENTING STANDARDS AND CODES	13
3.1 Solid-fuel Standards and Codes	13
3.2 Gas Standards and Codes	15
4. VENTING SYSTEM DESIGN	19
4.1 Gravity Systems	19
4.1.1 The chimney	19
4.1.2 The heating appliance	20
4.2 Mechanical Venting Systems	21
4.2.1 Location of a mechanical draft system	21
4.2.2 Installation at termination point	21
4.2.3 Installation on masonry chimneys	21
4.2.4 Chimney and flue sizing	21
5. MECHANICAL SYSTEM DESIGN	22
5.1 Design Guidelines for Mechanical Venting of Gas and Manually Fired Appliances	22
5.1.1 Fireplaces - wood or gas	22
5.1.2 Stoves and fireplace inserts	24
5.1.3 Other applications	24
6. GUIDE FOR MECHANICAL DRAFT SYSTEMS	25
6.1 Mechanical Draft System for Wood-Fired Fireplace with a Single Flue	25
6.2 Mechanical Draft System for Wood-Fired Fireplace with Multiple Flues	26
6.3 Mechanical Draft System for Wood-Fired Fireplace with Safety System per NFPA211/IMC-2000 edition	27
6.4 Mechanical Draft System for a Wood-fired Fireplace with Manual Damper and Safety System per NFPA211/IMC-2000 edition	28
6.5 Mechanical Draft System for Gas-Fired Fireplace with a Single Flue with Safety System per NFPA54/IFGC	29
6.6 Mechanical Draft System (automated) for a Gas-Fired Fireplace with a Single Flue with Safety System per NFPA54/IFGC	30
6.7 Mechanical Draft System for Gas-Fired Fireplace with Multiple Flues with Safety System per NFPA54/IFGC	31
6.8 Mechanical Draft System for Gas-Fired Fireplace with Multiple flues and Safety System per NFPA54/IFGC	32
6.9 Mechanical Draft System for Gas-Fired Fireplace with Damper and Safety System per NFPA54/IFGC	33
6.10 Mechanical Draft System (automated) for a Gas-Fired Fireplace with Modulating Fan Speed and a Single Flue with Safety System per NFPA54/IFGC	34
6.11 Mechanical Draft System for a Gas-Fired Fireplace with Modulating Fan Speed, Damper and a Single Flue with Safety System per NFPA54/IFGC	35
6.12 Mechanical Draft System for a Gas-fired Fireplace with Modulating Fan Speed and Multiple flues and Safety System per NFPA54/IFGC	36
7. FREQUENTLY ASKED QUESTIONS	37
APPENDIX A: DESIGN THEORY	38
APPENDIX B: CONVERSION TABLE FROM RECTANGULAR TO ROUND FLUES....	42
APPENDIX C: RESISTANCE FACTORS	42
SOURCES AND REFERENCES	43

Introduction

The primary purpose of this manual is to provide more detailed guidance on gravity venting and mechanical venting of decorative wood- or gas-fired heating appliances than can be found in the codes or in the appliance manufacturers' instructions. It is intended for the convenience and assistance of contractors, chimney sweeps, fireplace stores, building inspectors, architects, engineers and others concerned with the correct installation and configuration of gravity and mechanical venting systems.

The manual contains extensive information about chimney problems, how they can be solved, how to analyze and how to calculate venting system requirements for fireplaces and stoves. It also contains information about how to adapt mechanical venting for different applications.

Finally, for those who have an interest in a theoretical approach, the manual's appendix contains relevant theory regarding chimney systems for fireplaces and stoves.

Remember: A well-designed and well-functioning venting system is more important for successful wood and gas burning than a good stove or fireplace. This is reviewed throughout this manual.

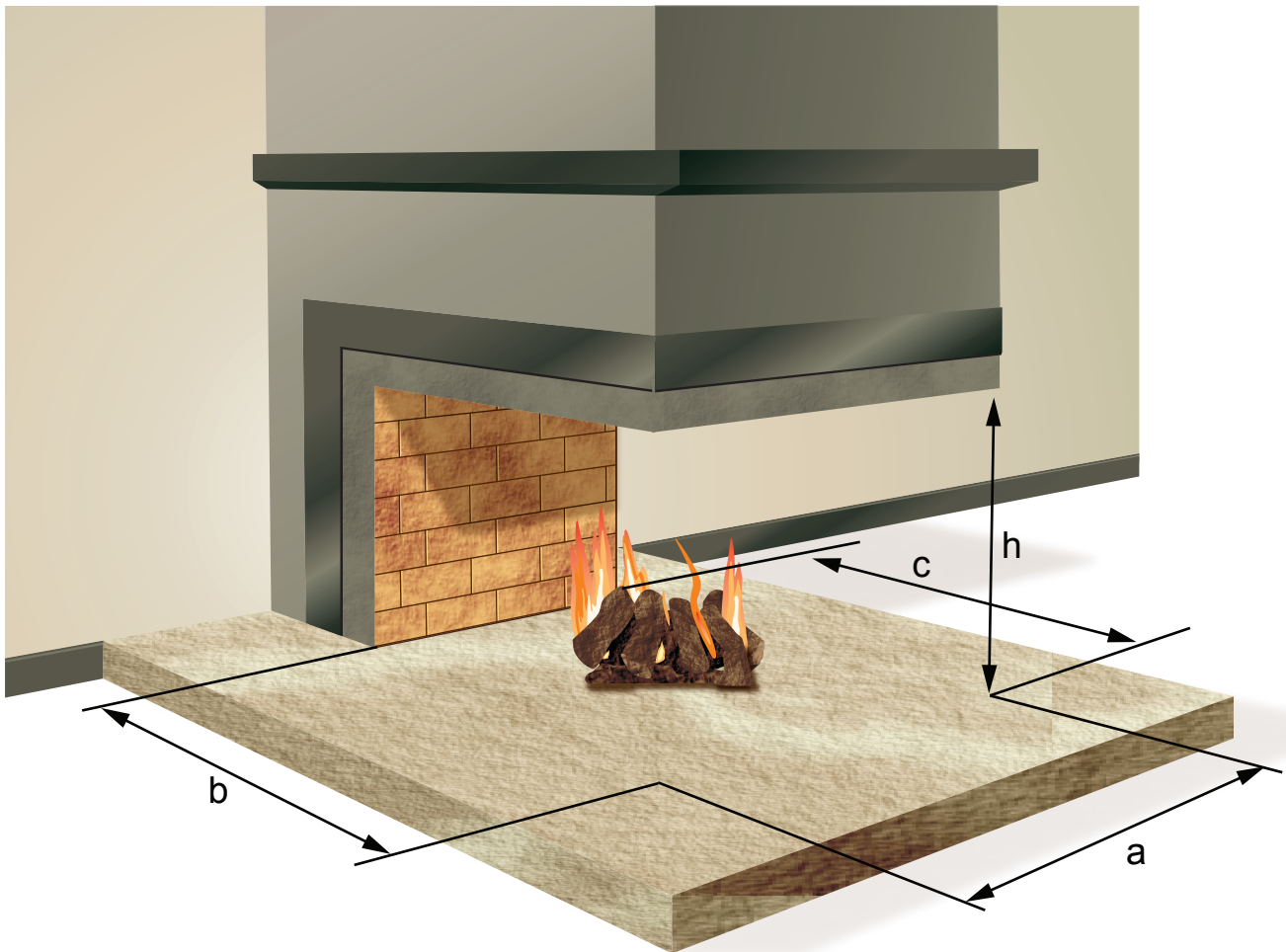



1. Venting in General

1.1 Designing Venting Systems

Open-fired heating appliances, like fireplaces, with natural draft chimneys, follow the same gravity fluid flow laws as gas vents and thermal flow ventilation systems. All thermal or buoyant energy is converted into flow, and no draft exists over the fire or the appliance inlet.

Up to some limiting value, mass flow of hot flue gases through a vertical pipe is a function of the rate of heat release, the chimney area, height and system pressure loss coefficient. An open-fired heating appliance may be considered as a gravity duct inlet fitting with a characteristic entrance-loss coefficient and an internal heat source. The heating appliance functions properly (does not smoke) when adequate intake or face velocity across those critical portions of the frontal opening nullifies external drafts and internal convection effects.

A mean flow velocity into a heating appliance's frontal opening is nearly constant from 300°F gas temperature rise up to any higher temperature. Local velocities vary within the opening, depending on its design, because the air enters horizontally along the hearth and then draws into the fire and upward, clinging to the back wall as shown below:

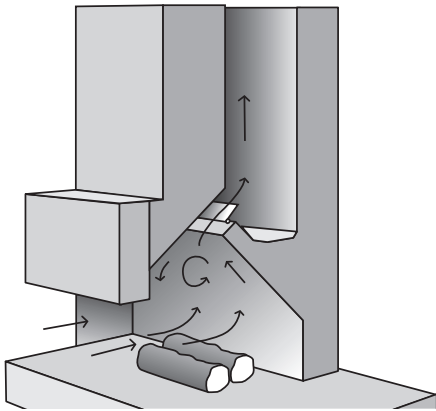

A recirculating eddy forms just inside the upper half of the opening, induced by the high velocity of flow along the back. Restrictions or poor construction in the throat area between the lintel and the damper also increases the eddy. Because the eddy moves smoke out of the zone of maximum velocity, the tendency of this smoke to escape must be counteracted by some minimum inward air movement over the entire front of the fireplace, particularly under the lintel.

1.2 Gravity vs. Mechanical Venting

Heating appliances can be vented by gravity or by mechanical means. "Gravity vented" is also called "naturally vented".

Gravity venting uses the difference in gravity of cold vs. warm air to create draft for the heating appliance. Gravity venting is very sensitive to the temperature of the products of combustion, the ambient/outdoor temperature, the barometric pressure and wind. It is difficult, if not impossible, to adjust the draft to changing conditions.

Mechanical venting uses a fan, blower or similar to create proper draft. It is not sensitive to the same issues as gravity venting, and it is possible to adjust the draft to meet changing conditions.

Gravity venting is by far the most popular method of venting a heating appliance. However, mechanical venting is becoming more popular, and for some heating appliances it has become an integrated part essential for maintaining proper draft and combustion and reducing emissions.

Many believe they know how gravity venting works, but very few can explain how a chimney works and why. Few really know how a mechanical venting system works, but many think they do. Chimney size, location and weather variations can have a large impact on a gravity vented chimney system. Misconceptions and misapplications cause these systems not to function as they are expected to. There are also many misconceptions about mechanical venting. While there is fear that installing a mechanically vented system will create a hazardous situation, mechanical venting is a safe and efficient way to vent a heating appliance.

The definition of a Mechanical Draft System can be found in NFPA 97, Standard Glossary of Terms Relating to Chimneys, Vents, and Heat-Producing Appliances:

"Equipment installed in and made part of a duct, chimney, or vent, that provides an induced draft"

Forced Draft: *"Where a fan is located so as to push the flue gases through the chimney or vent"*

Induced Draft: *"Where a fan is located so as to pull the flue gases through the chimney or vent"*

Obviously, a mechanical draft system cannot be used in any stack or chimney exposed to habitable space if it pressurizes the chimney or vent. Products of combustion will be forced out through cracks in the chimney, and this will create a potentially hazardous or dangerous condition, due to the presence of carbon monoxide.

On the other hand, a mechanical draft system installed at the termination point can be used on any type of chimney because it maintains a negative pressure in the entire system.

2. Venting Problems and Possible Solutions

As mentioned earlier, a well-designed and well-functioning venting system is more important for successful wood and gas burning than a good stove or fireplace.

Chimneys operate based on the simple principle that warm air rises because it has a lower density than cold air. Warmer flue gases in the chimney create buoyancy called “draft”, and the rising gases create a partial vacuum at the bottom of the chimney and appliance outlet.

What are thought to be “draft problems” may actually be chimney performance problems and are seldom caused by inadequate draft. They are more often caused by poor design and caused by the chimney itself.

There are two major factors to consider when working with chimneys: “draft” and “flue gas volume” (or flow). “Draft” is the force, which causes the flue gases to be exhausted. The “flue gas volume” is the amount of the products of combustion from the heating appliance passing through the system as a result of the draft.

The sizing of a chimney should be based on the flow requirements, as any chimney size has a certain capacity in regards to the amount of flue gases it is able to remove safely. A good analogy is drinking straws. Blowing into a small straw is more difficult than blowing into a large straw, and you can blow more air through the large one. A chimney works the same way: A greater volume of air can flow through a large flue easier than a small one.

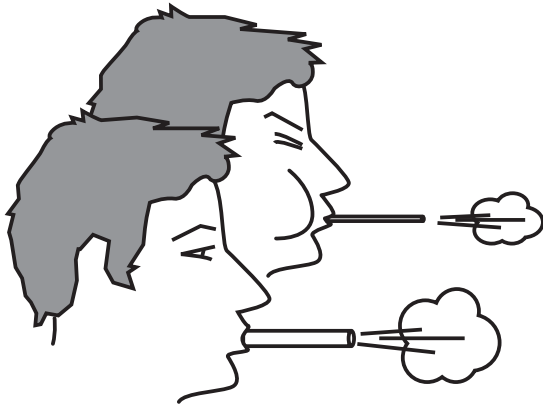

Two major factors influence the chimney capacity: “draft” and “flow resistance”. “Flow resistance” is a result of friction and always exists between the moving gases and the chimney through which they flow. Bends and elbows cause flow resistance, but even a straight pipe can cause flow resistance through friction.

The surface of the pipe is also important. A corrugated or rough surface causes more flow resistance than a smooth surface.

For a venting system to work properly, the draft **MUST** exceed the flow resistance. Otherwise there will be no movement of flue gases.

2.1 Chimney Performance Problems

The principles of flow and draft apply to all heating appliances.

Open heaters (open fireplaces, BBQ’s etc.) require a large chimney capacity, as they exhaust a relatively large volume of flue gases. They allow more dilution air, or excess air, to be introduced. As a result, they draw more room air, which lowers the flue gas temperature. A lower flue gas temperature means less draft is required for operation.

Closed heaters (stoves, fireplaces with doors, inserts, ovens etc.) burn more slowly and with much less dilution air. Thus there is less flue gas volume at a higher temperature, so this means more draft is required.

Open heaters are more susceptible to draft performance problems, but the following venting problem descriptions apply to all heating appliances:

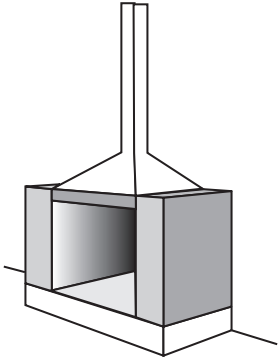
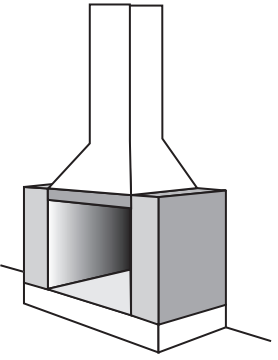
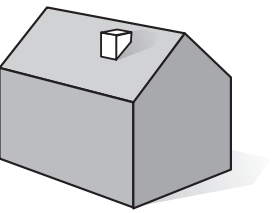

2.1.1. Problems associated with the venting system

Problem	Description	Can Occur when..	Possible Solutions
<p>The chimney flue is too small.</p> 	<p>A chimney may be severely restricted if the inner diameter of the flue is too small. The velocity of the flue gas reaches a point where the flow resistance is so substantial that the flow resistance exceeds the draft.</p> <p>See also "Oversized Fireplace Opening".</p>	<ul style="list-style-type: none"> • A chimney is relined and the diameter thus reduced. • A one-sided fireplace is converted into a see-through fireplace. • The chimney is improperly designed (undersized) to begin with. • An existing chimney is used for a heating appliance it was not designed for. 	<ul style="list-style-type: none"> • Redesign and rebuild the chimney to meet the draft requirements. • Install a heating appliance that does not exceed the capacity of the existing chimney. • Close off one side of a see-through fireplace • Reduce the opening of the fireplace. (Installing glass doors will not help unless the glass doors are designed to be closed during fireplace operation) • Install a mechanical venting system
<p>The chimney flue is too large.</p> 	<p>While increasing the flue size increases the capacity of a chimney, it can potentially reduce the available draft. Gases move more slowly in a large flue, and a large flue has more thermal mass (and more surface area) than a small flue. More heat is transferred from the flue gas to the chimney, which adversely affects the draft.</p> <p>Extreme cooling of the chimney can offset gains in capacity (see also "The chimney is installed on an outside wall")</p>	<ul style="list-style-type: none"> • Stove or fireplace insert is connected into an existing chimney that previously served a wood-burning fireplace. • A wood-burning fireplace is converted into a gas-fired fireplace and the existing chimney is used. • A set of gas logs is installed in a wood-burning fireplace. • The chimney is improperly designed to begin with. 	<ul style="list-style-type: none"> • Reline the chimney to reduce the flue opening and match the requirements of the appliance it serves. • Convert the gas-fireplace back to its original wood-burning design. • Install a mechanical venting system
<p>The chimney is too short</p> 	<p>A tall chimney creates more draft than a short chimney. Chimney height and the difference between flue gas and the temperature of the outside air are major factors which influence the amount of draft. A rule of thumb for minimum height is a total system height (from bottom of appliance to the top of the chimney) of not less than 15'. If the chimney is too short, it could also lead to improper termination. The termination should generally be at least 3 feet above anything within 10 feet of the chimney.</p>	<ul style="list-style-type: none"> • The chimney is on a slanted roof • The chimney is improperly designed to begin with. 	<ul style="list-style-type: none"> • Extend the chimney by adding chimney sections or tiles. If a system meets the recommended minimum height and draft problems are experienced, extending the chimney height may or may not have an effect. Try with a temporarily installed chimney pipe or steel pipe to verify this will in fact solve the problem. • Install a mechanical venting system

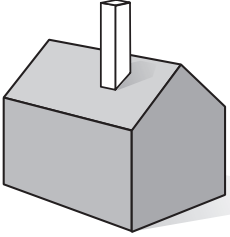
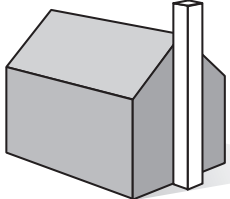
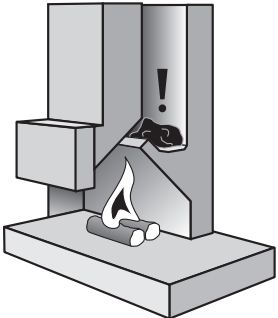
Problem	Description	Can Occur when..	Possible Solutions
<p>The chimney is too high.</p> 	<p>Increasing the height of a chimney increases the draft. Draft increases in proportion with chimney height but only to a certain point. At some point, additional height gives the flue gases more time to transfer heat to the flue walls and cool off. This will cause a reduction in the available draft.</p> <p>If a system meets the recommended minimum height and draft problems are experienced, it may or may not have any effect to extend the chimney height.</p>	<ul style="list-style-type: none"> • The chimney is serving a fireplace in a multistory building (apartment complex) • A large part of the chimney is exposed to the outside. 	<ul style="list-style-type: none"> • Reduce the height • Insulate the chimney • Install a mechanical venting system
<p>The chimney is placed outside the building envelope</p> 	<p>If one or more sides of a chimney are exposed to the outside, the chimney can experience excess cooling, which will reduce the draft. The chilling effect can be so bad that the exhaust gas is not able to create any draft at all – at least not during start-up. The best location of a chimney is within the building so only a very small part of the chimney is exposed to the outside.</p>	<ul style="list-style-type: none"> • The chimney is installed on an outside wall. • The chimney is not insulated • The chimney is installed in a location that meets code but is detrimental to proper draft. 	<ul style="list-style-type: none"> • Reline the chimney and/or provide better insulation • Install a mechanical venting system
<p>Obstructions or blockages in the venting system</p> 	<p>A chimney can be obstructed by debris, such as leaves, mortar left over during construction, or an animal or bird building a nest. Creosote build-up could also be blocking the flue or the chimney cap. Blockages might occur in deteriorating chimneys if parts of the interior collapses.</p>	<ul style="list-style-type: none"> • The flue liner is deteriorating. • Bird nests have been built outside the heating season. 	<ul style="list-style-type: none"> • Scan the inside of the chimney in search for obstructions blockages. Repair if deteriorations are found. • Remove animal's nests. • Clean the chimney for creosote or debris



2.1.2 Problems associated with the heating appliance

The chimney is not the only culprit. The heating appliance itself can be the problem and cause spillage or improper combustion. Heating appliance problems

depend on the appliance type. Fireplaces and stoves experience different problems:

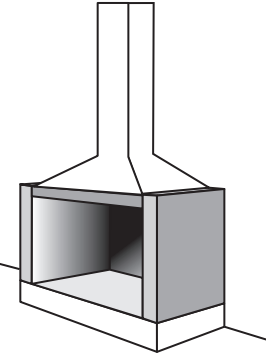
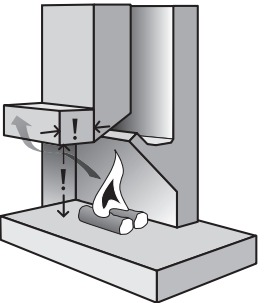
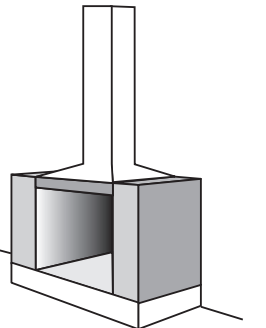
Problem	Description	Can Occur when..	Possible Solutions
<p>Oversized fireplace opening</p> 	<p>Generally speaking, there should be a 1:10 relationship in the cross-sectional area between flue size and fireplace opening. A 24"x 36" fireplace opening equals 864 sq.in., so the cross-sectional area of the flue should be at least 86 sq.in. This is equivalent to a 10" ID flue.</p>	<ul style="list-style-type: none"> • The fireplace has been redesigned to add more front area. • The fireplace is not designed properly to begin with. 	<ul style="list-style-type: none"> • Reduce the opening by installing a steel shield at the top of the fireplace opening. The height can be determined by using the 1:10 rule. Example: the fireplace opening is 40"x25" or 1,000 sq.in and the flue size is 10" ID – or 86 sq.in. Reduce the fireplace opening to 860 sq.in. by blocking off 140 sq.in on top. 140 divided by 40 equals 3.5" which should be the height of the shield. • Reduce the opening by rebuilding it. • If the lintel is less than 6" below the damper assembly, it should be extended. Or, add a shield as described above. • Install a mechanical draft system.
<p>The lintel may be too small or too deep</p> 	<p>The lintel prevents the smoke from rolling out by capturing and containing it – it serves the same purpose as the front edge of a kitchen hood. If it is too deep or too small, it may not be able to capture and contain the smoke.</p>	<ul style="list-style-type: none"> • The fireplace is not designed properly to begin with. 	<ul style="list-style-type: none"> • Increase the height of the lintel. • Decrease the depth of the lintel. • Install a mechanical draft system.
<p>The smoke chamber is improperly designed</p> 	<p>The smoke chamber guides the smoke towards the chimney flue. If there is no smoke chamber, or it's too low, the smoke stays in the throat or the firebox and becomes turbulent after which it will start spilling. The smoke chamber should be centered with the sides angled at not less than 45°. It could also be that the inside construction is irregular with protrusions.</p>	<ul style="list-style-type: none"> • The fireplace is not designed properly to begin with. 	<ul style="list-style-type: none"> • Increase the height of the smoke chamber. • Parge the smoke chamber walls or otherwise smooth the sides. • Install a mechanical draft system.

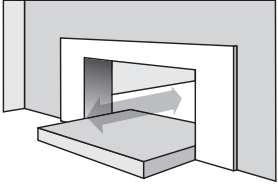
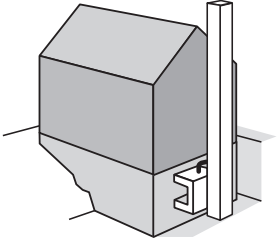
Problem	Description	Can Occur when..	Possible Solutions
<p>The appliance is a see-through fireplace</p> 	<p>Among critical fireplaces is the so-called “see-through” fireplace – a fireplace that is open into two rooms. The fireplaces must capture the air in the same way as an exhaust hood, which requires good draft in order to maintain a high velocity over the fireplace opening. Very often turbulence can be experienced inside the smoke chamber, and smoke problems can occur.</p>	<ul style="list-style-type: none"> • Fireplace was converted from a one-sided fireplace into a see-through • No smoke chamber • Opening up into rooms with different pressures (one room has stairs, vaulted ceiling etc., the other one does not) 	<ul style="list-style-type: none"> • Close one side of the see-through fireplace. • Redesign the smoke chamber to provide a better flow. • Redesign and rebuild the chimney to provide the proper draft. • Install a mechanical draft system
<p>The appliance is in the wrong place.</p> 	<p>Performance problems can also be experienced if the appliance is in the wrong place. The chimney is put in an impossible situation where it is not given a chance to work.</p>	<ul style="list-style-type: none"> • A fireplace or stove located in the basement of a building. • The chimney makes too many changes of directions (too many elbows) to get flue gases from the appliance to the outside. 	<ul style="list-style-type: none"> • Redesign the venting system – if possible • Remedies to increase frontal velocity include the following: (1) increase chimney height (using the same flue area) and extend the last tile 6 inches or more upward; (2) decrease frontal opening by lowering the lintel or raising the hearth (glass doors may help); and (3) increase the free area through the damper (ensure that it opens fully and without interference). • Install a mechanical draft system



2.1.3 Problems associated with the building/house

In the past, heating engineers often used high indoor pressure to keep cold air from infiltrating. When houses were leaky (before energy awareness), it was thought better to force warm air out through cracks to prevent cold air from infiltrating. In current homes and buildings, pressurized conditioned air is being

pushed through walls and ceilings. If the pressurized air is moist – which it often is – water is being pushed into the walls where it will soak the insulation. This can lead to mold, mildew or rot.

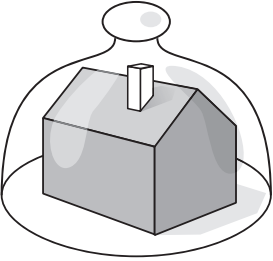
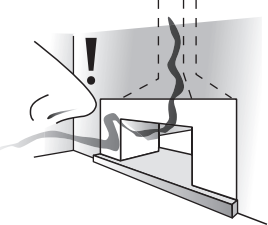
Problem	Description	Can Occur when..	Possible Solutions
<p>The building is too tight</p> 	<p>A heating appliance needs air for the combustion process. If the building is tight and the proper amount of combustion air can not be supplied, a smoking fireplace or stove may be the result. If opening a window or door close to the fireplace solves the problem, an outside air supply should be installed.</p>	<ul style="list-style-type: none"> • The house is built too tight to begin with. • New and better insulated windows have been installed. • The building has been properly insulated. 	<ul style="list-style-type: none"> • Install a properly sized outside air intake ducted to the bottom of the fireplace. This must be relatively large and should in most cases exceed a 6 inch ID. Actual size depends on the fireplace opening. It could be powered by a fan or blower. • Provide supply air to the room in which the fireplace is located. • Install a mechanical venting system, but make sure air can be drawn into the room in which the fireplace is located, and it does not adversely affect the operation of other heating appliances.
<p>There are odors from the heating appliance when not used</p> 	<p>Draft is highly dependant on barometric pressure and temperature. On a hot, humid and rainy day there is not much natural draft in a chimney and the flow may reverse causing it to produce the odor. This is more of an indoor air quality problem than a draft problem. The chimney may work fine once a fire is built in the heating appliance.</p>		<ul style="list-style-type: none"> • Have the chimney cleaned thoroughly and make sure all creosote has been removed. • Install a chimney cap • Install a tight fitting chimney top mounted damper • Install a tight fitting set of glass doors • Install a mechanical draft system

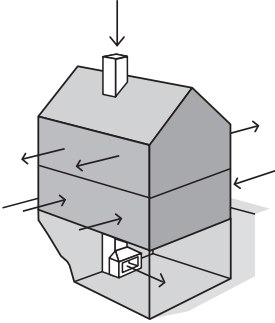
Problem	Description	Can Occur when..	Possible Solutions
<p data-bbox="175 214 461 268">Stack effect created inside the building</p> 	<p data-bbox="495 214 792 697">Stack effect is a symptom primarily experienced in multistory buildings. The stack effect in itself is not a problem. It is a very common phenomenon in high-rise buildings where it is 'enhanced' by the existence of elevators that constantly change the pressure when ascending and descending. Efforts to 'control' the stack effect often lead to a pressurized building, so by 'solving' one problem, another – worse problem could be created.</p> <p data-bbox="495 714 803 1197">In some literature, expressions like “high-pressure plane”, “low-pressure plane” and “neutral-pressure plane” can be found. These expressions are used in conjunction with fire-rating of doors, and have no scientific meaning within the building science. “Stack-effect” is a word used in the science of IAQ, or Indoor Air Quality, as an explanation of how pollutants are transported within a building.</p> <p data-bbox="495 1213 787 1522">Open-fired heating appliances often experience draft problems when exposed to the stack effect. The chimney draft is eliminated due to negative pressure at the inlet of the heating appliance, so spillage occurs immediately during start-up.</p>	<ul data-bbox="820 214 1079 298" style="list-style-type: none"> • Heating appliances are placed in multi-story buildings. 	<ul data-bbox="1140 214 1445 840" style="list-style-type: none"> • Install a mechanical air supply fan to provide air into the building close to where the heating appliance is located. • “Isolate” the heating appliance from the negative pressure by building a room to place the appliance, and supply combustion air to it. • Install a mechanical venting system. Installing a mechanical venting system is often the simplest, most effective and least expensive solution to stack effect problems. Other solutions can interfere dramatically with the building operation and lead to dismal energy efficiency.

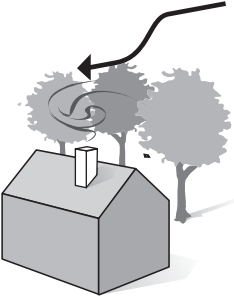
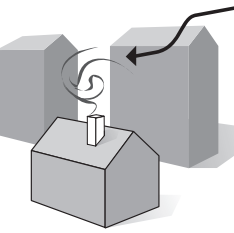
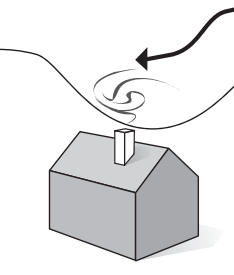

2.1.4 Problems associated with the building's environment

Problem	Description	Can Occur when..	Possible Solutions
<p>Tall trees surrounding the building</p> 	<p>It doesn't take much to affect the draft. A tall tree in the vicinity of the chimney can create turbulence that, at times, may cause spillage in the heating appliance served by the chimney.</p> <p>A problem like this could literally have been growing over the years. It is not uncommon that a fireplace that has been working well for years suddenly experiences draft problems due to trees growing around the building.</p>	<ul style="list-style-type: none"> • Trees are growing and getting taller over the years 	<ul style="list-style-type: none"> • Raise the chimney • Cut down trees • Install a mechanical draft system
<p>There is a taller building next door</p> 	<p>Just like a tree, the neighboring building can cause similar problems. It may be a taller building that affects the wind flow patterns and cause flow reversal in the chimney.</p>	<ul style="list-style-type: none"> • New building is constructed on the neighboring lot. 	<ul style="list-style-type: none"> • Raise the chimney • Install a mechanical draft system
<p>The building is located in a valley or surrounded by taller buildings</p> 	<p>A building in a valley can find itself in a low pressure area (inversion) which can adversely affect the draft. Inversions are common in hilly or mountainous areas. A building surrounded by taller buildings can experience similar problems.</p>		<ul style="list-style-type: none"> • Install a mechanical draft system

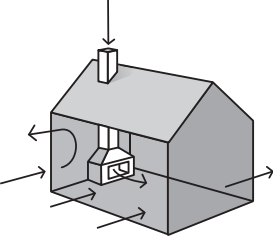
Problem	Description	Can Occur when..	Possible Solutions
<p>The wind is creating a downdraft</p>  <p>The diagram shows a 3D perspective of a house with a chimney on the roof. Arrows indicate wind blowing from the left side of the house. A downward arrow points from the chimney, representing the downdraft. Inside the house, arrows point towards the fireplace, indicating the flow of air being pulled down.</p>	<p>Wind induced downdraft is a common draft problem – and often it’s only occasional. It may only occur on a windy day when the wind is blowing from a certain direction. Wind induced downdraft is caused by “eddies” – or flow patterns around the building and the chimney.</p>	<ul style="list-style-type: none"> • The downdraft can be caused by windloading. This is a scenario where eddies, or flow patterns, create an unfavorable draft condition. When the wind hits one side of the building it tends to create a positive pressure on this side (windward side). This is balanced out by a negative pressure on the opposite side (leeward side). This phenomenon can create pressure changes inside the building which can adversely affect fireplace operation. • This is often experienced at oceanfront or lakefront properties and ones located in mountainous areas. 	<ul style="list-style-type: none"> • Install a chimney cap • Extend the chimney beyond the eddy • Install a mechanical draft system



3. Venting Standards and Codes

All types of venting of a heating appliance, whether this is wood or gas fired, are governed by a national or local code.

The standards can be made by an independent organization, like National Fire Protection Association (NFPA) or by industry-related organizations. These standards can, by choice, be adopted by a state, a county, a city or another local jurisdiction.

In the venting area, the applicable code depends on the fuel used. Pay special attention to the code version in effect. Local jurisdictions don't always follow the latest version of a standard. Some may still use a 1992 version while others have adopted the most recent version.

For solid-fuel fired applications the following standards and codes usually apply:

- NFPA211, Standard for Chimneys, Fire places, Vents, and Solid Fuel-Burning Appliances
- IMC, International Mechanical Code

For gas-fired applications these apply:

- NFPA54 / ANSI Z223.1 National Fuel Gas Code
- IFGC, International Fuel Gas Code

In very general terms, there are no major differences in the way the different codes govern gravity venting. This is not the case when it comes to mechanical venting, so this section will concentrate on the codes and standards surrounding mechanical venting of heating appliances.

The concerns surrounding mechanical venting are about how to handle the "flow of fuel" in case the mechanical draft system experiences an electrical or mechanical failure.

3.1 Solid-fuel standards and codes

The most important part of the venting code deals with the minimum performance. It says:

4.1.1 Minimum Performance. A chimney or vent shall be so designed and constructed to develop a flow sufficient to remove completely all flue or vent gases to the outside atmosphere.

4.1.1.1 Chimneys or vents shall be evaluated to ensure proper performance with respect to draft, creosote buildup, and condensation.

4.1.1.2 The venting system shall satisfy the draft requirements of the connected appliance(s) in accordance with the manufacturers' instructions or approved methods.

(NFPA 211, 2006 Edition, pg. 211-13)

It's worth mentioning that according to the code, a smoking fireplace is in fact a code violation that requires a correction.

The NFPA 211 standard allows the use of mechanical venting under certain conditions depending on the version adopted.

According to the 2006 edition, a mechanical draft system must meet these requirements:

4.1.2 Mechanical Draft Systems. A listed mechanical draft system of either forced or induced draft design shall be permitted to be used to increase draft or capacity.

4.1.2.1 Where a mechanical draft system is installed, provision shall be made to prevent the flow of fuel to an automatically fired appliance(s) when that system is not operating.

4.1.2.2 The operation of a mechanical draft system shall not adversely affect the performance or safety of, or cause spillage of combustion products from, other combustion equipment operating within the same building.

4.1.2.3 Proper performance and safety of other combustion equipment shall be verified by testing prior to the mechanical draft system being put into service.

4.1.2.4 Such testing shall include operation of the mechanical draft system together with other exhaust equipment likely to operate simultaneously.

4.1.2.5 Mechanical draft systems of either forced or induced draft serving manually fired appliances shall be one of the following:

(1) A mechanical draft system that is an integral part of a listed appliance.

(2) A solid fuel cooking appliances as addressed in NFPA 96, *Standard for Ventilation Control and Fire Protection of Commercial Cooking Operations*.

(3) *An engineered mechanical draft system that includes the following provisions:

(a) The following detection and warning devices shall be installed and line voltage devices, when installed, shall be provided with a battery backup system:

i. A device that produces an audible and visible warning upon failure of the mechanical draft system.

The device shall be activated by loss of electrical power supply or by operational failure of the mechanical draft system, at any time while the mechanical draft system is switched on.

ii. A smoke detector and alarm installed and maintained in accordance with NFPA 72, *National Fire Alarm Code*®. The detector shall be installed in the same room as the appliance served by the mechanical draft system.

iii. A listed carbon monoxide warning device installed in accordance with the manufacturers' instructions.

(b) The mechanical draft system shall be listed in accordance with UL 378, *Standard for Draft Equipment*, for use with the type of appliance and range of chimney service appropriate for the application. The mechanical draft system shall not cause or permit blockage of the flue or electrical hazard after exposure to a chimney fire or over fire conditions. The mechanical draft system shall be installed in accordance with the terms of the listing and the manufacturers' instructions.

(c) The mechanical draft system shall be sized to maintain draft within the range specified by the appliance manufacturer.

(NFPA 211, 2006 Edition, pg. 211-13 and 211-14)

The termination of a venting system including a mechanical draft system follows other requirements as described in the following:

10.4 Termination (Height).

10.4.1 All vents shall terminate above the roof surface.
Exception: Pellet vents and other vents as provided in 10.4.5 and Section 10.7.

10.4.1.1 Vents installed with mechanical exhausters shall terminate not less than 12 in. (305 mm) above the highest point where they pass through the roof surface.

10.4.1.2 Vents installed with a listed cap shall terminate in accordance with the terms of the cap's listing.

10.4.1.3 Vents installed without listed caps or mechanical exhausters shall extend 2 ft (0.61 m) above the highest point where they pass through the roof surface of a building and at least 2 ft (0.61 m) higher than any portion of a building within 10 ft (3.1 m). [See Figure 4.2(a) and 4.2(b).]

10.4.2 Natural draft vents for gas appliances shall terminate at an elevation not less than 5 ft (1.53 m) above the highest connected appliance outlet.
Exception: As provided in 10.4.3 and 10.7.2.

10.4.3 Natural draft gas vents serving vented wall furnaces shall terminate at an elevation not less than 12 ft (3.7 m) above the bottom of the furnace.

10.4.4 Vents passing through roofs shall extend through the roof flashing.

10.4.5 Mechanical draft systems shall not be required to comply with 10.4.1 and 10.4.3, provided they comply with the following:

- (1) The exit terminal of a mechanical draft system other than a direct vent appliance (sealed combustion system appliance) shall be located in accordance with the following:
 - a. Not less than 3 ft (0.92 m) above any forced air inlet located within 10 ft (3.1 m)
 - b. Not less than 4 ft (1.2 m) below, 4 ft (1.2 m) horizontally from, or 1 ft (305 mm) above any door, window, or gravity air inlet into any building

c. Not less than 2 ft (0.61 m) from an adjacent building and not less than 7 ft (2.1 m) above grade where located adjacent to public walkways

- (2) The exit terminal shall be so arranged that flue gases are not directed so that they jeopardize people, overheat combustible structures, or enter buildings.
- (3) Forced draft systems and all portions of induced draft systems under positive pressure during operation shall be designed and installed to be gastight or to prevent leakage of combustion products into a building.
- (4) Through-the-wall vents for gas appliances shall not terminate over public walkways or over an area where condensate or vapor could create a nuisance or hazard or could be detrimental to the operation of regulators, relief valves, or other equipment.

(NFPA 211, 2006 Edition, pg. 211-31 and 211-32)

IMC
The International Mechanical Code is virtually in full agreement with NFPA 211:

804.3.7 Exhauster sizing. Mechanical flue exhausters and the vent system served shall be sized and installed in accordance with the manufacturer's installation instructions.

804.3.8 Mechanical draft systems for manually fired appliances and fireplaces. A mechanical draft system shall be permitted to be used with manually fired appliances and fireplaces where such system complies with all of the following requirements:

1. The mechanical draft device shall be listed and installed in accordance with the manufacturer's installation instructions.
2. A device shall be installed that produces visible and audible warning upon failure of the mechanical draft device or loss of electrical power, at any time that the mechanical draft device is turned on. This device shall be equipped with a battery backup if it receives power from the building wiring.
3. A smoke detector shall be installed in the room with the appliance or fireplace. This device shall be equipped with a battery backup if it receives power from the building wiring.

(IMC, 2009 Edition, pg. 73)

Just as the NFPA 211 describes termination requirements, almost identical requirements can be found in the IMC:



804.3 Mechanical draft systems. Mechanical draft systems of either forced or induced draft design shall comply with Sections 804.3.1 through 804.3.7.

804.3.1 Forced draft systems. Forced draft systems and all portions of induced draft systems under positive pressure during operation shall be designed and installed so as to be gas tight to prevent leakage of combustion products into a building.

804.3.2 Automatic shutoff. Power exhausters serving automatically-fired appliances shall be electrically connected to each appliance to prevent operation of the appliance when the power exhauster is not in operation.

804.3.3 Termination. The termination of chimneys or vents equipped with power exhausters shall be located a minimum of 10 feet (3048 mm) from the lot line or from adjacent buildings. The exhaust shall be directed away from the building.

804.3.4 Horizontal terminations. Horizontal terminations shall comply with the following requirements:

1. Where located adjacent to walkways, the termination of mechanical draft systems shall be not less than 7 feet (2134 mm) above the level of the walkway.
2. Vents shall terminate at least 3 feet (914 mm) above any forced air inlet located within 10 feet (3048 mm).
3. The vent system shall terminate at least 4 feet (1219 mm) below, 4 feet (1219 mm) horizontally from or 1 foot (305 mm) above any door, window or gravity air inlet into the building.
4. The vent termination point shall not be located closer than 3 feet (914 mm) to an interior corner formed by two walls perpendicular to each other.
5. The vent termination shall not be mounted directly above or within 3 feet (914 mm) horizontally from an oil tank vent or gas meter.
6. The bottom of the vent termination shall be located at least 12 inches (305 mm) above finished grade.

804.3.5 Vertical terminations. Vertical terminations shall comply with the following requirements:

1. Where located adjacent to walkways, the termination of mechanical draft systems shall be not less than 7 feet (2134 mm) above the level of the walkway.
2. Vents shall terminate at least 3 feet (914 mm) above any forced air inlet located within 10 feet (3048 mm).
3. Where the vent termination is located below an adjacent roof structure, the termination point shall be located at least 3 feet (914 mm) from such structure.
4. The vent shall terminate at least 4 feet (1219 mm) below, 4 feet (1219mm) horizontally from, or 1 foot (305 mm) above any door, window or gravity air inlet for the building.

5. A vent cap shall be installed to prevent rain from entering the vent system.
6. The vent termination shall be located at least 3 feet (914 mm) horizontally from any portion of the roof structure.

804.3.6 Exhauster connections. An appliance vented by natural draft shall not be connected into a vent, chimney or vent connector on the discharge side of a mechanical flue exhauster.

(IMC, 2009 Edition, pg. 72-73)

3.2 Gas Standards and Codes

Mechanical venting of gas-fired appliances has become an accepted standard. Many of today's heating appliances rely on mechanical venting to perform and meet efficiency and emission standards.

Despite the growing popularity, some appliance manufacturers are still reluctant to allow the use of mechanical venting to vent their appliances. Since they don't have any support from the standards and codes, their reluctance is usually an indication of lack of knowledge rather than a lack of adaptability.

If an appliance's installation manual says that it must be installed according to NFPA 54/ANSI Z223.1 or similar this means a mechanical draft system can be used. Only if the installation manual specifically limits its use by a statement like: "Mechanical venting is not acceptable" should the use of a mechanical draft system be avoided.

A manufacturer can not deny warranty coverage if the conditions below are met.

12.1 Minimum Safe Performance. A venting system shall be designed and constructed so as to develop a positive flow adequate to convey flue or vent gases to the outdoors.

12.4.1 Appliance Draft Requirements. A venting system shall satisfy the draft requirements of the appliance in accordance with the manufacturer's instructions.
(NFPA54/ANSI Z223.1, 2009 Edition, pg. 84)

Just as solid fuel-burning equipment, gas equipment must meet minimum performance requirements:

503.3 Design and construction. A venting system shall be designed and constructed so as to develop a positive flow adequate to convey flue or vent gases to the outdoors.

503.3.1 Appliance Draft Requirements. A venting system shall satisfy the draft requirements of the appliance in accordance with the manufacturer's instructions.

(IFGC, 2009 Edition, pg. 81)

NFPA54 / ANSI Z223.1:

In this code the installation of a mechanical draft system must meet the following requirements:

12.4.3 Mechanical Draft Systems.

12.4.3.1 Mechanical draft systems shall be listed and shall be installed in accordance with both the appliance and the mechanical draft system manufacturer's installation instructions.

12.4.3.2 Appliances requiring venting shall be permitted to be vented by means of mechanical draft systems of either forced or induced draft design.

Exception: Incinerators.

12.4.3.3 Forced draft systems and all portions of induced draft systems under positive pressure during operation shall be designed and installed so as to prevent leakage of flue or vent gases into a building.

12.4.3.4 Vent connectors serving appliances vented by natural draft shall not be connected into any portion of mechanical draft systems operating under positive pressure.

12.4.3.5 Where a mechanical draft system is employed, provision shall be made to prevent the flow of gas to the main burners when the draft system is not performing so as to satisfy the operating requirements of the appliance for safe performance.

12.4.3.6 The exit terminals of mechanical draft systems shall be not less than 7 ft (2.1 m) above grade where located adjacent to public walkways and shall be located as specified in 12.9.1 and 12.9.2.

(NFPA 54/ANSI Z223.1, 2009 Edition, pg. 84)

From this it is clear that any type of gas utilization equipment, except for incinerators, can be vented by means of a mechanical draft system. As the code notes one exception only, this means that any type fireplace, stove, gas heater, furnace etc. that is gas fired can be vented mechanically.

12.7.2 Gas Vent Termination. The termination of gas vents shall comply with the following requirements:

(1) A gas vent shall terminate in accordance with one of the following:

(a) Gas vents that are 12 in. (300 mm) or less in size and located not less than 8 ft (2.4 m) from a vertical wall or similar obstruction shall terminate above the roof in accordance with Figure 12.7.2 and Table 12.7.2.

(b) Gas vents that are over 12 in. (300 mm) in size or are located less than 8 ft (2.4 m) from a vertical wall or similar obstruction, shall terminate not less than 2 ft (0.6 m) above the highest point where they pass through the roof and not less than 2 ft (0.6 m) above any portion of a building within 10 ft (3.0 m) horizontally.

(c) Industrial appliances as provided in 12.3.4.

(d) Direct-vent systems as provided in 12.3.5.

(e) Appliances with integral vents as provided in 12.3.6.

(f) Mechanical draft systems as provided in 12.4.3.

(f) Ventilating hoods and exhaust systems as provided in 12.4.4.

(NFPA 54/ANSI Z223.1, 2009 Edition, pg. 54-87)

IFGC:

The International Fuel Gas Code is almost identical to the National Fuel Gas Code, which is clear when reviewing the following and comparing it to NFPA 54 Par. 10.3.4.:

503.3.3 Mechanical Draft Systems. Mechanical draft systems shall comply with the following:

1. Mechanical draft systems shall be listed and shall be installed in accordance with the manufacturer's installation instructions for both the appliance and the mechanical draft system.
2. Appliances, except incinerators, requiring venting shall be permitted to be vented by means of mechanical draft systems of either forced or induced draft design.
3. Forced draft systems and all portions of induced draft systems under positive pressure during operation shall be designed and installed so as to prevent leakage of flue or vent gases into a building.
4. Vent connectors serving appliances vented by natural draft shall not be connected into any portion of mechanical draft systems operating under positive pressure.
5. Where a mechanical draft system is employed, provisions shall be made to prevent the flow of gas to the main burners when the draft system is not performing so as to satisfy the operating requirements of the appliance for safe performance.
6. The exit terminals of mechanical draft systems shall be not less than 7 ft (2134 mm) above grade where located adjacent to public walkways and shall be located as specified in Section 503.8, Items 1 and 2.

(IFGC, 2009 Edition, pg. 81)



The International Fuel Gas Code is also virtually identical to NFPA 54 when it comes to the venting termination:

503.6.4 Gas vent terminations. A gas vent shall terminate in accordance with one of the following:

1. Gas vents that are 12 inches (305 mm) or less in size and located not less than 8 feet (2438 mm) from a vertical wall or similar obstruction shall terminate above the roof in accordance with Figure 503.6.4.
2. Gas vents that are over 12 inches (305 mm) in size or are located less than 8 feet (2438 mm) from a vertical wall or similar obstruction shall terminate not less than 2 feet (610 mm) above the highest point where they pass through the roof and not less than 2 feet (610 mm) above any portion of a building within 10 feet (3048 mm) horizontally.
3. As provided for industrial equipment in Section 503.2.2.
4. As provided for direct-vent systems in Section 503.2.3.
5. As provided for appliances with integral vents in Section 503.2.4.
6. As provided for mechanical draft systems in Section 503.3.3.
7. As provided for ventilating hoods and exhaust systems in Section 503.3.4.

(IFGC, 2009 Edition, pg. 84)

The International Fuel Gas Code is also virtually identical to NFPA 54 when it comes to venting appliances:

503.2.2 Well-ventilated spaces. Where located in large and well-ventilated space, industrial appliances shall be permitted to be operated by discharging the flue gases directly into the space.

503.2.3 Direct-vent appliances. Listed direct-vent appliances shall be installed in accordance with the manufacturer's instructions and Section 503.8, Item 3.

503.2.4 Appliances with integral vents. Appliances incorporating integral venting means shall be considered properly vented where installed in accordance with the manufacturer's instructions and Section 503.8, Items 1 and 2.

503.3.4 Ventilating hoods and exhaust systems. Ventilating hoods and exhaust systems shall be permitted to be used to vent appliances installed in commercial applications. Where automatically operated appliances are vented through a ventilating hood or exhaust system equipped with a damper or with a power means of exhaust, provisions shall be made to allow the flow of gas to the main burners only when the damper is open to a position to properly vent the appliance and when the power means of exhaust is in operation.

(IFGC, 2009 Edition, pg. 80)

4. Venting System Design

4.1. Gravity Systems

4.1.1 The chimney

Chimneys come in different types, shapes and sizes. The two main types of chimneys are: metal and masonry.

Metal chimneys are available in different types of metal, including 430, 304, 316 or AL29-4C stainless steel, or it could be in aluminum. Metal chimneys are also called “pre-fabricated”, “Class A”, “Type B” as well as “single-wall”, “double-wall”, “triple-wall” or “zero-clearance”. Although they all serve the same purpose - to remove products of combustion and maintain proper draft – each type has limitations in the application in which it can be applied.

A “pre-fabricated” chimney is a chimney that is made as a standard product using a standardized manufacturing method and is made with a joint-system that makes it easy to install in the field. Virtually all metal chimneys are “pre-fabricated”. One exception, however, is the welded single-wall steel pipe which is typically designed and assembled via welding in the field.

The table below shows each chimneys application and listing:

Metal chimneys are available in many sizes, some

from 4 inch ID all the way up to 60 inch ID. Sizes up to 12 inch ID are often considered “residential” sizes while sizes larger than 12 inch are considered “commercial”. The size of a chimney affects its capacity and how much product of combustion it can remove. Each size has a specific usable area, which is called the “effective area”. This area, along with the chimney height, determines the chimney’s capacity.

It is important to understand that the cross-sectional area grows exponentially as the ID increases. For example, a 6 inch ID chimney has a cross-sectional area of approx. 28 sq.in, while an 8 inch ID chimney has a cross-sectional area of approx. 50 sq.in. Increasing the ID by 33%, the cross-sectional area increased by almost 80% - and so did the chimney’s capacity. Increasing the ID from 6” to 12” (100% increase) increases the cross-sectional area by 400%!

Masonry chimneys are normally built using brick and mortar. The products of combustion are conveyed through a flue or liner in the center of the chimney. This flue or liner can be square, rectangular, oval or round.

Just as steel chimneys, a masonry chimney has an effective area. Only a certain area of a flue is used due to general airflow patterns or characteristics.

Uses	Gas Appliance Vent	Chimney Liner		Building Heating Appliance Chimney		Pellet Vent	Special Gas Vent
Fuel	Nat. Gas, Propane and LP only	Nat. Gas, Propane and LP only	Nat. Gas, Propane, LP, Oil, Solid Fuel	Nat. Gas, Propane, LP, Oil, Solid Fuel	Nat. Gas, Propane, LP, Oil, Solid Fuel	Pellets, Nat. Gas, Propane, LP and Oil	Nat. Gas, Propane, LP and Oil
Test Standard	UL441	UL1777	UL103	UL103	UL103	UL641	UL1738
Max. Operating Temperature	400°F above ambient	400°F above ambient	1000°F 1400°F 1 Hour 2100°F 10 Min.	1000°F 1400°F 1 Hour 2100°F 10 Min. *)	1000°F 1400°F 1 Hour 2100°F 10 Min.	500°F above ambient	Single Wall: 480°F Double Wall: 550°F
Operating Conditions	Gravity or induced flow, neutral and negative pressure	Gravity or induced flow, neutral and negative pressure	Gravity or induced flow, neutral and negative pressure	Gravity or induced flow, neutral and negative pressure	Gravity or induced flow, neutral, negative and positive pressure	Gravity or induced flow, neutral and negative pressure	Gravity or induced flow, neutral and negative pressure
Appliances	Listed gas appliances and other appliances listed for venting with Type B gas vent	Listed gas appliances and other appliances listed for venting with Type B gas vent	Listed building heating appliances including fireplaces and stoves	Listed building heating appliances including fireplaces and stoves	Listed building heating appliances including fireplaces and stoves	Pellet fueled and certain gas, or oil appliances	Listed gas or oil fired building heating appliances and other
Material: - inner - outer	Aluminium Aluminum/galv. steel	Aluminum N/A	Stainless steel	304/430 SS 430 or Galv. Steel	304/316 SS Alumnized steel	430 SS Alumnized steel	AL29-4C Alumnized steel
Codes & Standards	NFPA54, NFPA211	NFPA54, NFPA211	NFPA37, NFPA54, NFPA211	NFPA37, NFPA54, NFPA211	NFPA37, NFPA54, NFPA211	NFPA211	NFPA37, NFPA54,
Mechanical Draft System Location	Termination only	Termination only	Termination only	Termination only	Termination or in-line	Termination only	Termination or in-line



The figure below shows the effective area of different flue shapes:

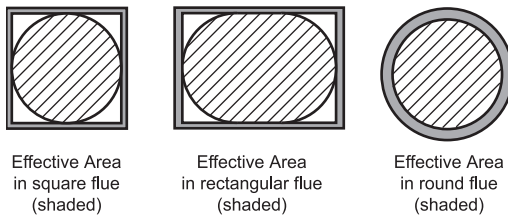

The effective area can be calculated by first determining the hydraulic diameter. More on this subject can be found in Section 5.1.1.

4.1.2 The heating appliance

Designing a gravity venting system is relatively simple, but depends on the appliance in use.

4.1.2.1 Pre-fabricated fireplace for wood or gas with integrated chimney.

This has become a very popular type of fireplace in new construction and it can be gas or wood fired. The chimney has already been sized for the fireplace and all that can vary is the chimney height – at least within some mandated minimum and maximum heights. One 30° offset is typically allowed.

The chimney size selection is often based on the volume of the firebox, and there is no scientific selection method behind it. The method used is often like “a 2 cu.ft. firebox requires a 6 in chimney, a 3 cu.ft. firebox requires an 8 in chimney” and so forth.

If an installation does fall within the recommendations given by the manufacturer then there is not much assistance available. The manufacturers may not be ‘experts’ in venting issues and may state that using a mechanical draft system will void their warranty or the product listing.

If the appliance’s installation manual demands that the installer follows NFPA211 and/or NFPA54 then that entire standard text must be followed. If the standard allows mechanical venting, and the installation manual does not clearly prohibit this, then the manufacturer cannot deny such installation neither can he reject warranty coverage.

4.1.2.2 Pre-fabricated fireplace for wood or gas

This type does not include an integrated chimney. The chimney must be supplied by the installer. However, the fireplace manufacturer must provide sizing and type recommendations for the installer and the recommendations are very much like what you find for the fireplaces that integrate the chimney.

4.1.2.3 Pre-fabricated wood or coal stoves

Stoves are supplied without a chimney. Again the chimney must be supplied by the installer, unless an existing chimney is used for the venting.

The manufacturers’ recommendations are limited to type of chimney, diameter, maximum number of elbows and height restrictions.

4.1.2.4 Custom-made heating appliances

Custom-made heating appliances, such as masonry fireplaces that are wood or gas fired, are more challenging as there is no manufacturer to provide any sizing recommendations. The sizing must be determined by the designer or the installer.

The sizing can be performed in a number of ways depending on the application.

In all open-fired heating appliances a minimum frontal inlet velocity of 0.8 feet per second in conjunction with a chimney gas temperature of at least 300-500°F above ambient, should control smoking in a well-constructed conventional masonry fireplace. The chart on page 24 shows fireplace and chimney dimensions for the specific conditions of circular flues at 0.8 feet per second frontal velocity. This chart readily accounts for maximum frontal opening for a given chimney, as well as for chimney size and height with a predetermined opening. The figure assumes no wind or air supply difficulties.

It may also be adequate to use the 1:10 rule where the cross-sectional area of the chimney flue must be min. 10% of the fireplace opening area.

Other applications may include fireplaces with more than one side or opening, horizontal runs or a number of different elbows, tee’s and more. For these an ‘approved engineering method’ must be used such as prescribed in the ASHRAE Handbook in the Equipment Volume, Chapter 30 for “Chimneys, Gas Vent, and Fireplace Systems”.

The design should follow these steps:

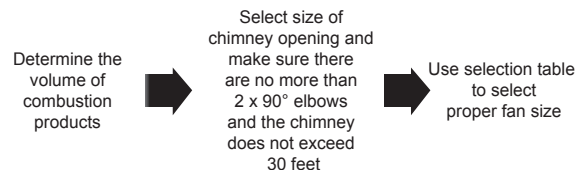

Indoor-outdoor pressure differences caused by winds, building stack effect, and operation of forced-air heating systems or mechanical ventilation affect the operation of a fireplace. Thus, smoking during start up can be caused by many factors unrelated to the chimney. Often, in new homes (especially in high-rise multiple-family construction), fireplaces

of normal design cannot cope with mechanically induced reverse flow or shortages of combustion air. In such circumstances, a fireplace should include a mechanical draft system of sufficient capacity to overcome other mechanized air-consuming systems.

4.2 Mechanical Venting Systems

Designing and sizing of a mechanical draft system must be performed using an “approved engineering method” such as prescribed in the ASHRAE Handbook in the Equipment Volume, Chapter 30 for “Chimneys, Gas Vent, and Fireplace Systems”.

4.2.1 Location of a Mechanical Draft System

A mechanical draft system can be installed at the termination point or in-line between the appliance and the termination point.

In-line mechanical draft systems can only be used when the flue or chimney is airtight downstream from its location. The table on page 20 shows which chimney types can use mechanical draft systems and where they should be located.

4.2.2 Installation at Termination Point

When used with a pre-fabricated chimney system, the mechanical draft system should be installed on a special chimney adapter that gives proper support of the additional weight. It is usually not necessary to provide special support for the system as long as the chimney is terminated within 1-5 feet from the roof support.

If the chimney is a type that requires ventilation between the chimney walls outside the flue, special precaution must be taken not to block the passageways. This can be accomplished by using an adapter that provides an opening of 1 inch between the termination of the chimney and the bottom of the fan (adapter).

4.2.3 Installation on Masonry Chimneys

In most cases, a mechanical draft system can be installed directly on the chimney where the flue terminates. The system is placed directly over the flue in lieu of a chimney cap.

Aesthetics:

From an aesthetical point of view, the installation of a mechanical draft system is no different from the installation of a chimney cap.

However, sometimes a building design does not allow a visible chimney cap or fan. In those situations

it may be possible to recess the fan into the cavity of the chimney. The fan must have adequate ventilation available, so it cannot be completely enclosed. A 1-2 inch space or clearance around the sides of the fan is usually acceptable and the discharge can be through weep-holes on the side of the chimney or straight up. There should not be any restrictions.

4.2.4 Chimney and Flue Sizing

Sizing of chimney and flue is as important as for gravity venting.

Measures should be taken to assure that the flue size is adequate to allow for a velocity that does not exceed 1,500-1,800 feet per minute. A higher velocity will lead to flow noise - especially in steel chimneys.

On the other hand, the velocity should never fall below 300 feet per minute as this may lead to excessive build-up of creosote or condensate.

“Oversized flues” can also make it more difficult to install the mechanical draft system. Special adapters may be needed to prevent the mechanical draft system from falling into the flue.



5. Mechanical System Design

5.1 Design Guidelines for Mechanical Venting of Gas and Manually Fired Appliances

There are two ways to determine the chimney fan type and size for the specific application.

One alternative is to calculate the flue gas volume and the flow resistance and then select the chimney fan that meets the calculated requirements. This is normally referred to as an “approved engineered method”. For directions on how to do a manual calculation please refer to Appendix A.

Please note that the size and selection charts are based on elevation of up to 2,000 feet above sea level. For elevations greater than this please contact your supplier or call ENERVEX 800.255.2923 for assistance.

Height of chimney:	18-25 feet
Flue gas temperature:	
Wood	300°F
Gas	200°F
Frontal inlet velocity:	
Fireplace (wood-fired)	48 fpm
Fireplace (gas-fired)	36 fpm
Stoves (wood-fired)	84 fpm

The sizings and the selection charts in the following are based on these assumptions:

5.1.1 Fireplaces – wood or gas

Most applications are relatively simple, and following these four steps makes it easy to size a proper chimney fan for an application.

Step 1 - Determine the size of the appliance opening

Use the following charts to determine the opening of the appliance:

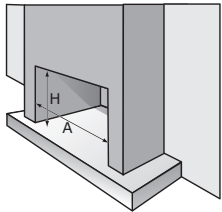
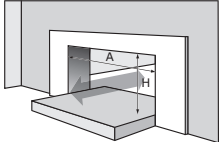
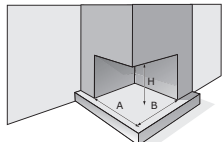
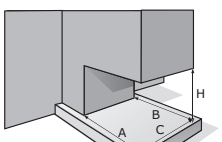
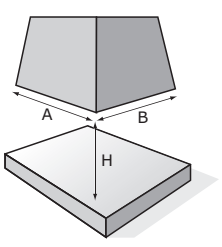
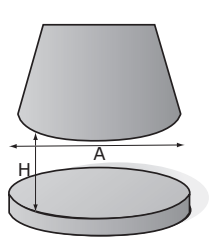
Fireplace Type	Formula to determine opening size	
One-sided	$A \times H$	
Two-sided (See-through)	$2 \times A \times H$	
Corner	$(A \times B) \times H$	
Three-sided	$(A+B+C) \times H$	
Free-standing	$(A+B) \times H \times 2$	
Free-standing round	$A \times H \times 3.14$	

Example: A two-sided fireplace measures 24" x 36" on the largest size. The opening measures 864 sq.in. Multiply by 2 and the opening used for the selection table is 1,728 sq.in.

Step 2 - Determine the size of the chimney opening

For this method a chimney or flue opening must be expressed as the inside diameter in inches. For a round chimney or flue this is not a problem as the size is expressed as 9"ID, indicating the inside diameter is 9".

Oval, square or rectangular chimney must first be converted to an equivalent ID. If the flue is a clay tile, then the table below shows the typical standard flue tile size along with the equivalent ID:

Outside Dimensions (inch)	Effective Flue Area (sq.in.)	Equivalent Diameter (ID) (inch)
4 1/2 x 8 1/2	23	5
4 1/2 x 13	34	6
8 x 8	42	7
8 1/2 x 8 1/2	49	8
8 x 12	67	9
8 1/2 x 13	76	10
8 1/2 x 18	102	11
12 x 12	102	11
12 x 16	131	13
13 x 13	127	12
13 x 18	173	14
16 x 16	181	15
16 x 20	222	16
18 x 18	233	17
20 x 20	298	19
20 x 24	335	20
24 x 24	431	23

Example: A fireplace is served by a flue that is 8" x 12" or 9 in ID.

Flue sizes not shown in above table can be converted using the table in Appendix B.

Step 3 - Check number of offsets and height

Check that there are no more than 2x90° elbows and no more than 30' of height. If there are more than 2x90° elbows, use a bigger fan or contact ENERVEX for a custom sizing.

Step 4 - Select a fan from the sizing table

The following table is used for fireplaces that are wood fired:

Eff. Flue ID	Fireplace Opening (sq.in.) - Wood					
	400	600	900	1,200	1,500	2,000
5	RSHT12	-	-	-	-	-
6	RSHT9	RSHT12	-	-	-	-
7	RSHT9	RSHT12	RSHT12	-	-	-
8	RSHT9	RSHT12	RSHT12	RSHT14	RSHT14	-
9	RSHT9	RSHT12	RSHT12	RSHT14	RSHT14	-
10	RSHT9	RSHT12	RSHT12	RSHT14	RSHT14	RSHT16
12	RSHT9	RSHT12	RSHT12	RSHT14	RSHT14	RSHT16
14	RSHT9	RSHT12	RSHT12	RSHT14	RSHT14	RSHT16
16	RSHT9	RSHT12	RSHT12	RSHT14	RSHT14	RSHT16
18	RSHT9	RSHT12	RSHT12	RSHT14	RSHT14	RSHT16
20	RSHT9	RSHT12	RSHT12	RSHT14	RSHT14	RSHT16

Note: The black background indicates that the fan will most likely create some air-flow noise due to a high air velocity in the chimney. The light grey background indicates the fan base will not cover the chimney opening and a special adapter must be used.

Example: We have calculated a 24" x 36" (864 sq.in.) wood-fired fireplace and a chimney flue at 8" x 12" or 9 in ID. Using the table we need to use a model RSHT12.

If the application involves a gas-fired appliance use this table:

Eff. Flue ID	Fireplace Opening (sq.in.) - Gas							
	400	600	1,000	2,000	2,500	3,000	3,500	5,000
5	RS9	RS12	-	-	-	-	-	-
6	RS9	RS9	RS14	-	-	-	-	-
7	RS9	RS9	RS12	-	-	-	-	-
8	RS9	RS9	RS9	RS16	-	-	-	-
9	RS9	RS9	RS9	RS14	RS16	-	-	-
10	RS9	RS9	RS9	RS12	RS14	RS16	-	-
12	RS9	RS9	RS9	RS12	RS14	RS14	RS16	-
14	RS9	RS9	RS9	RS12	RS14	RS14	RS14	-
16	RS9	RS9	RS9	RS12	RS14	RS14	RS14	RS16
18	RS9	RS9	RS9	RS12	RS14	RS14	RS14	RS16
20	RS9	RS9	RS9	RS12	RS14	RS14	RS14	RS16
22	RS9	RS9	RS9	RS12	RS14	RS14	RS14	RS16
24		RS9	RS9	RS12	RS14	RS14	RS14	RS16

Note: The black background indicates that the fan will most likely create some air-flow noise due to a high air velocity in the chimney. The light grey background indicates the fan base will not cover the chimney opening and a special adapter must be used.

Examples: We have calculated a 24" x 36" (864 sq.in.) gas-fired fireplace and a chimney flue at 8" x 12" or 9 in ID. Using the table we need to use a model RS 9 - one size smaller than the above sample using a wood-fired fireplace.



Special applications

Fireplaces with two flues:

When a fireplace is served by two flues of identical sizes, two fans are recommended – one for each flue. To size up such a system, take the total area of the appliance opening and divide by two. Then select fans as if there are two fireplaces each with one flue.

Example: A wood-fired fireplace with 2,400 sq.in. opening is served by two flues of each 8" x 12" or 9" ID each. Select fans by using 2,400 sq.in. opening divided by two or 1,200 sq.in. Using the sizing tables two RS 14's are needed.

In some situations, a single fan's capacity may be enough to handle a fireplace with two flues. If so, the fan should be installed so it can pull equally from the two flues. A good way to accomplish this is to install the fan on a plenum box so two flues can vent into a common area.

Fans used as a ventilator for odor control:

The fan can also be used for odor control. For sizing purposes it should be sized for the application following the above guidelines.

5.1.2 Stoves & Fireplaces Inserts

Sizing of mechanical venting for stoves and fireplace inserts follow the same guidelines as above.

Step 1 - Determine the size of the stove or insert opening

Measure the opening dimensions as shown on the figure below:

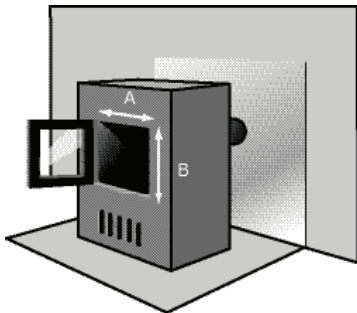

Step 2 - Determine the size of the chimney opening

Follow the procedure and the table used for fireplaces.

Step 3 - Check number of offsets and height

Check that there are no more than 2x90° elbows and no more than 30' of height.

If there is more than 2x90° elbows, use a bigger fan.

Step 4 - Select a fan from the sizing table

Select fan from sizing table

	Opening in sq.in.	
	Max. 300	Over 300
6	RS9	RS12
7	RS9	RS12
8	RS9	RS12
9	RS9	RS12
10	RS9	RS12

Use this chart to select the fan size:

5.1.3 Other Applications

If you need a chimney fan for an application that is not covered by the charts or if you are not sure about what's needed for your applications, please contact your supplier or call ENERVEX Inc. for assistance.

Go to www.chimneyfans.com for an easy-to-use sizing program

6. Guide for Mechanical Draft Systems

There are a number of different ways to use mechanical venting systems. The following presents a variety of these applications.

6.1 Mechanical Draft System for Wood-Fired Fireplace with a Single Flue

Application

This is the most common form of installation and is used in all jurisdictions where the 2000 or later edition of the NFPA211 has not yet been adopted.

Sequence of Operation

1. Prepare the wood logs in the fireplace.
2. Turn the Fan Speed Control (FSC) on by turning the knob clockwise. A “click” indicates the control is turned on. Adjust the knob to the desired speed.
3. Start the fire by igniting the logs.
4. Once the fire is fully burning, turn the dial clockwise (to reduce the speed) until there is spillage coming from the fireplace opening. Hot, moist heat rising from the top of the fireplace is an indication of spillage. From this point, gradually increase the fan speed by turning the dial counter-clockwise until no flue gases spill from the fireplace. The dial can be left in this position.
5. If logs are added to the fire, it may be necessary to increase the fan speed again.
6. When the fire is dying, reduce the speed setting further to remove remaining products of combustion.

IMPORTANT NOTE:

Never leave a fire unattended. When a fire is smoldering it is more likely to emit carbon monoxide.

You should always have a smoke detector and a carbon monoxide detector installed in the same room where the solid-fuel burning appliance is installed.

System 1

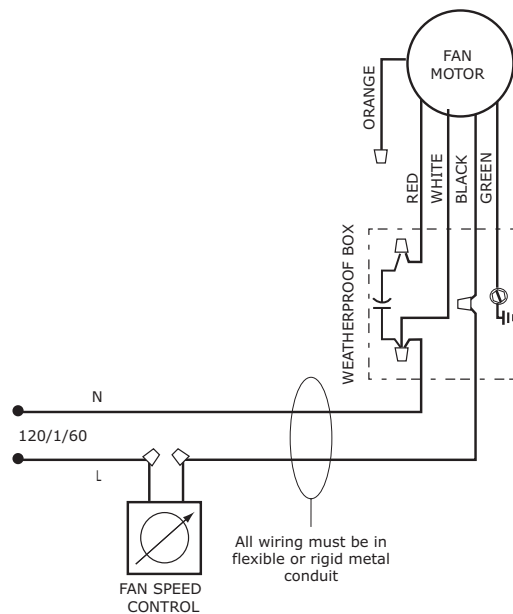
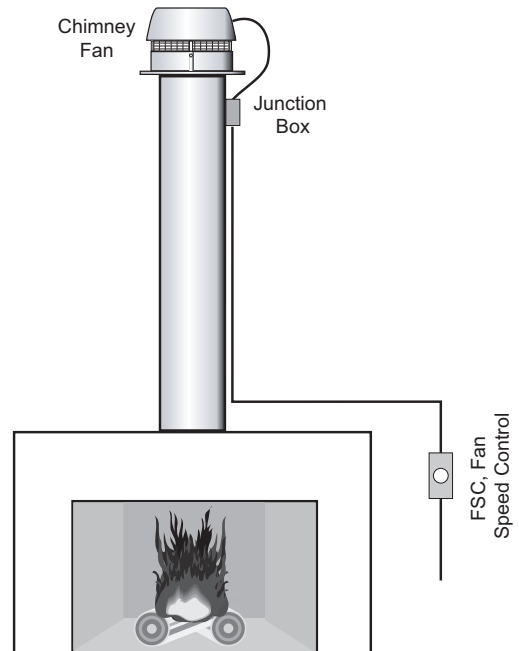

NOTES:

- 1 THE DISCONNECT MEANS AND CIRCUIT PROTECTION ARE TO BE PROVIDED BY THE INSTALLER OF THIS DEVICE

LEGEND:

- 24 VAC
- 120 VAC



6.2 Mechanical Draft System for Wood-fired Fireplace with Multiple Flues

Application

This is used in the same situations as System 1, but where multiple fans are required to handle the heat load. It is a typical installation for large fireplaces where a single flue cannot handle the amount of exhaust gases generated.

*For one fan serving two flues please refer to section 6.1 as the wiring diagram is identical. A special plenum box may be required.

Sequence of Operation

The sequence of operation is no different from System 1, but make sure a single fan speed control is simultaneously handling both fans.

1. Prepare the wood logs in the fireplace.
2. Turn the Fan Speed Control (FSC) on by turning the knob clockwise. A “click” indicates the control is turned on. Adjust the knob to the desired speed.
3. Start the fire by igniting the logs.
4. Once the fire is fully burning, turn the dial clockwise (to reduce the speed) until there is spillage coming from the fireplace opening. Hot, moist heat rising from the top of the fireplace is an indication of spillage. From this point, gradually increase the fan speed by turning the dial counter-clockwise until no flue gases spill from the fireplace. The dial can be left in this position.
5. If logs are added to the fire, it may be necessary to increase the speed again.
6. When the fire is dying, reduce the speed setting further to remove remaining products of combustion.

Please see important note on page 24.

System 2

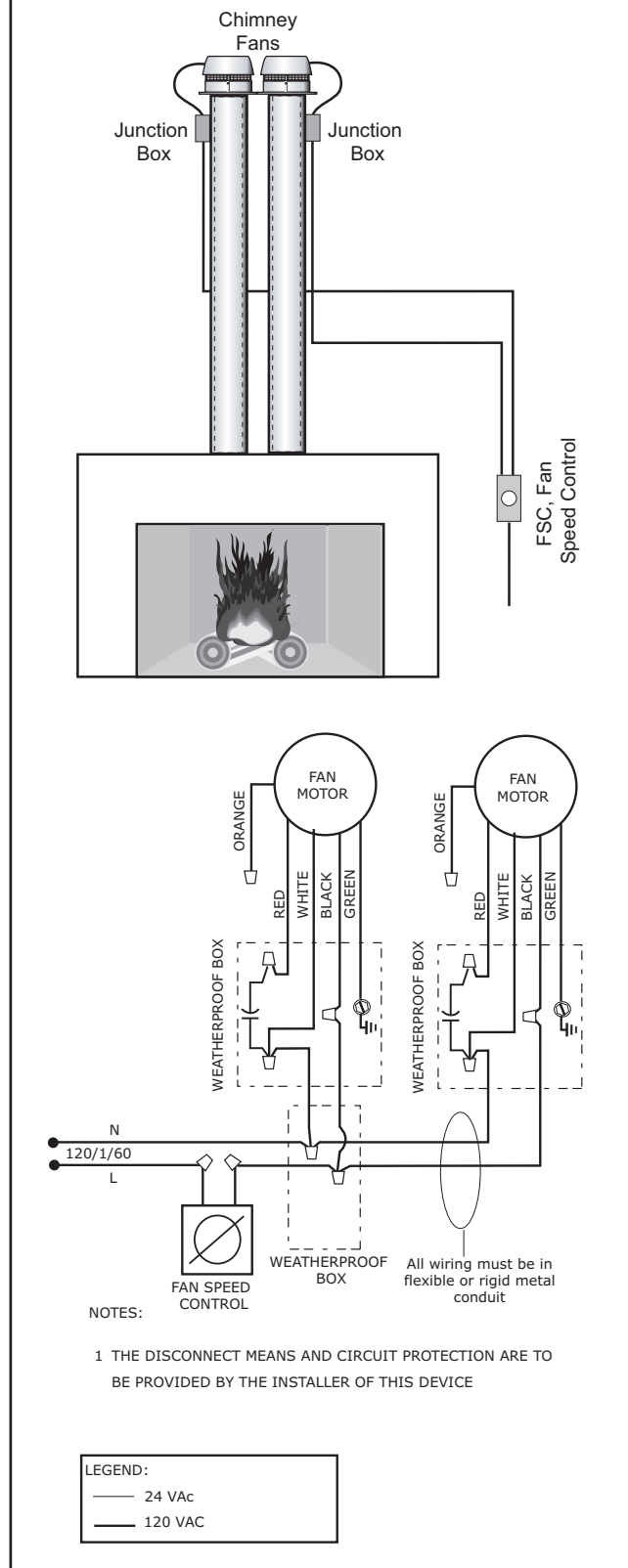

6.3 Mechanical Draft System for a Wood-fired Fireplace with Safety System per NFPA211/IMC-2000 edition (and after)

Application

In jurisdictions where the 2000 or later edition of the NFPA211 has been adopted, there are new requirements for the use of mechanical draft systems in conjunction with solid fuel. The installation requires a safety control such as the EFC 211 Fan Control.

Sequence of Operation

1. Turn the control on by turning the knob clockwise. A “click” indicates the control is turned on. Adjust the knob to the desired speed. The speed must be set so no smoke spills from the solid fuel heating appliance (fireplace, stove, wood-fired oven etc.) through the opening into a room. The smoke should be safely exhausted through the chimney.
2. The chimney fan will start with a 15 second boost to ensure proper fan operation and the green LED on the speed control unit cover will flash. After 15 seconds, the fan speed will be reduced to the preset level and continue to operate at this speed.
3. During appliance operation the speed setting can be adjusted if needed. This is especially true if logs are added.
4. The control constantly monitors the chimney fan operation. It automatically measures the fan speed every minute and if necessary, it increases the fan speed. This can be heard as quiet “hick-up” from the fan. If necessary, the control increases the fan speed to 100% for 15 seconds (green LED flashes), after which it will slow the fan speed down to set speed.
5. If the green LED flashes during operation (after the 15 seconds initiation) the fan speed is set too low or the fan wheel is somehow obstructed. If the red LED flashes and the buzzer sounds, the following may be the cause:
 - Blocked flue.
 - Defect chimney fan
 - Disconnected thermo-couple
 - Disconnected power supply The control can be reset, and the alarm turned off, by pressing the RESET button for 1-2 seconds.

Please see important note on page 24.

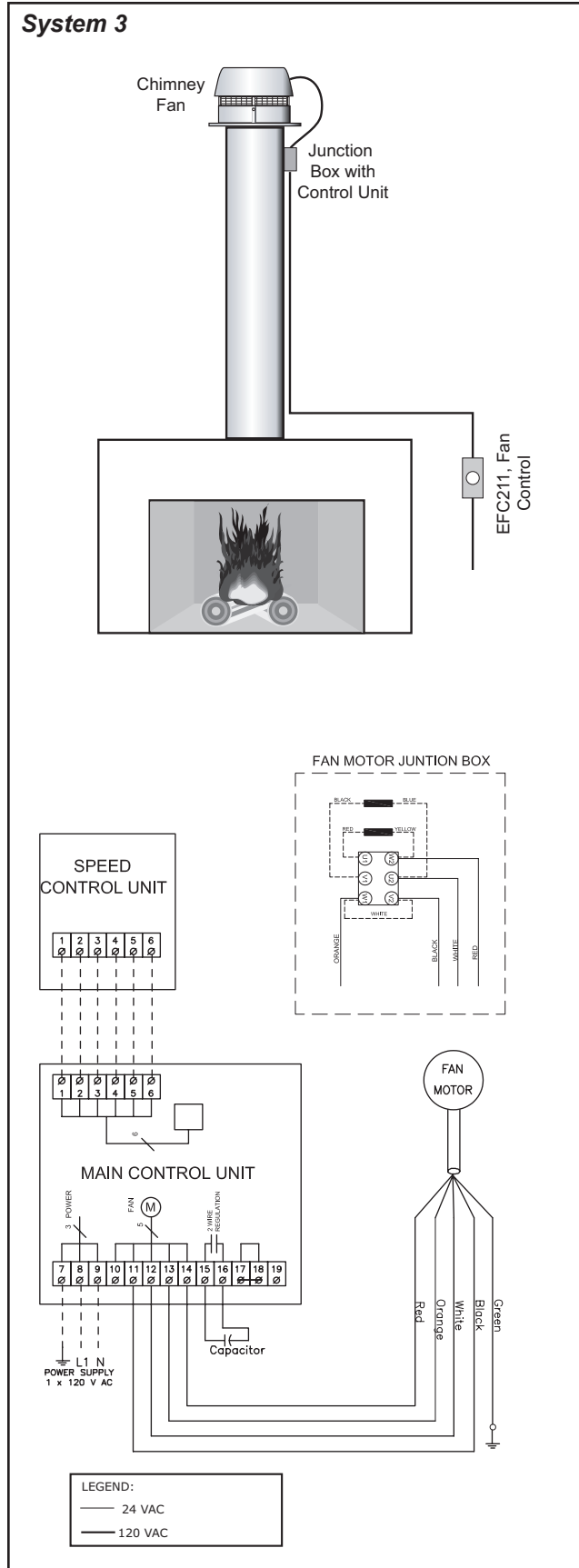

6.4 Mechanical Draft System for a Wood-fired Fireplace with Manual Damper and Safety System per NFPA211/IMC-2000 edition (and after)

Application

In jurisdictions where the 2000 or later edition of the NFPA211 has been adopted, there are new requirements for the use of mechanical draft systems in conjunction with solid fuel. The installation requires a safety control such as the EFC 211 Fan Control.

Sequence of Operation

1. Fully open the manual damper.
2. Turn the control on by turning the knob clockwise. A “click” indicates the control is turned on. Adjust the knob to the desired speed. The speed must be set so no smoke spills from the solid fuel heating appliance (fireplace, stove, wood-fired oven etc.) through the opening into a room. The smoke should be safely exhausted through the chimney.
3. The chimney fan will start with a 15 second boost to ensure proper fan operation. and the green LED on the speed control unit cover will flash. After 15 seconds, the fan speed will be reduced to the preset level and continue to operate at this speed.
4. During appliance operation the speed setting can be adjusted if needed. This is especially true if logs are added.
5. The control constantly monitors the chimney fan operation. It automatically measures the fan speed every minute and if necessary, it increases the fan speed. This can be heard as quiet “hick-up” from the fan. If necessary, the control increases the fan speed to 100% for 15 seconds (green LED flashes), after which it will slow the fan speed down to set speed.
6. If the green LED flashes during operation (after the 15 seconds initiation) the fan speed is set too low or the fan wheel is somehow obstructed. If the red LED flashes and the buzzer sounds, the following may be the cause:
 - Blocked flue.
 - Defect chimney fan
 - Disconnected thermo-couple
 - Disconnected power supply The control can be reset, and the alarm turned off, by pressing the RESET button for 1-2 seconds.

Please see important note on page 24.

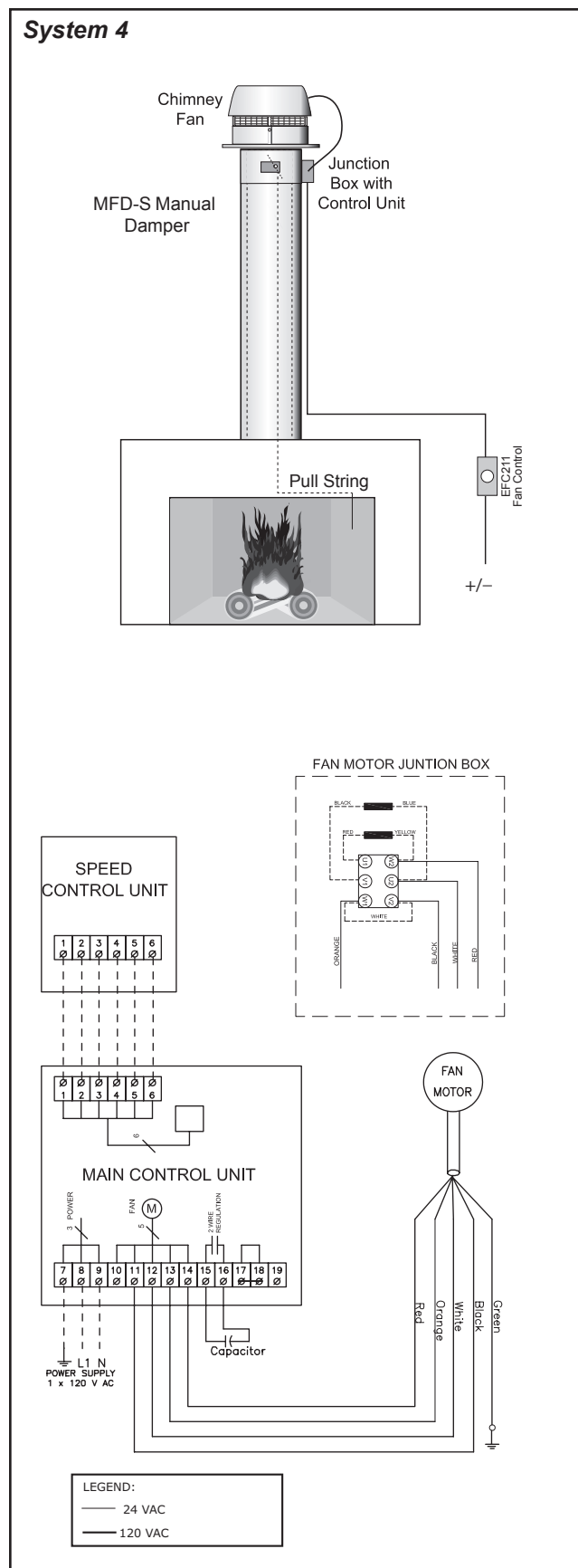

6.5 Mechanical Draft System for a Gas-Fired Fireplace with a single flue with Safety System per NFPA54/IFGC

Application

This is the simplest form of installation when used with a gas fireplace. The set-up can be used with virtually any type of gas-fired heating appliance.

Sequence of Operation

1. Turn the fan speed control on by turning the knob clockwise. A “click” indicates the control is turned on. Adjust the knob to the desired speed.
2. Start the fire by pushing the igniter or other means used to start the fire.
3. Fine-tune the fan speed setting so spillage from the fireplace opening can not be detected. Hot, moist heat rising from the top of the fireplace is an indication of spillage. For better detection, hold a mirror over the fireplace opening
4. In case of mechanical or electrical fan failure, the proven draft switch will disconnect the flow of fuel to the fireplace or the gas logs.
5. Once the proper draft has been established in the chimney, the proven draft switch will close to allow the flow of fuel.
6. When the fan is turned off, the proven draft switch will open and automatically turn off the flow of gas.

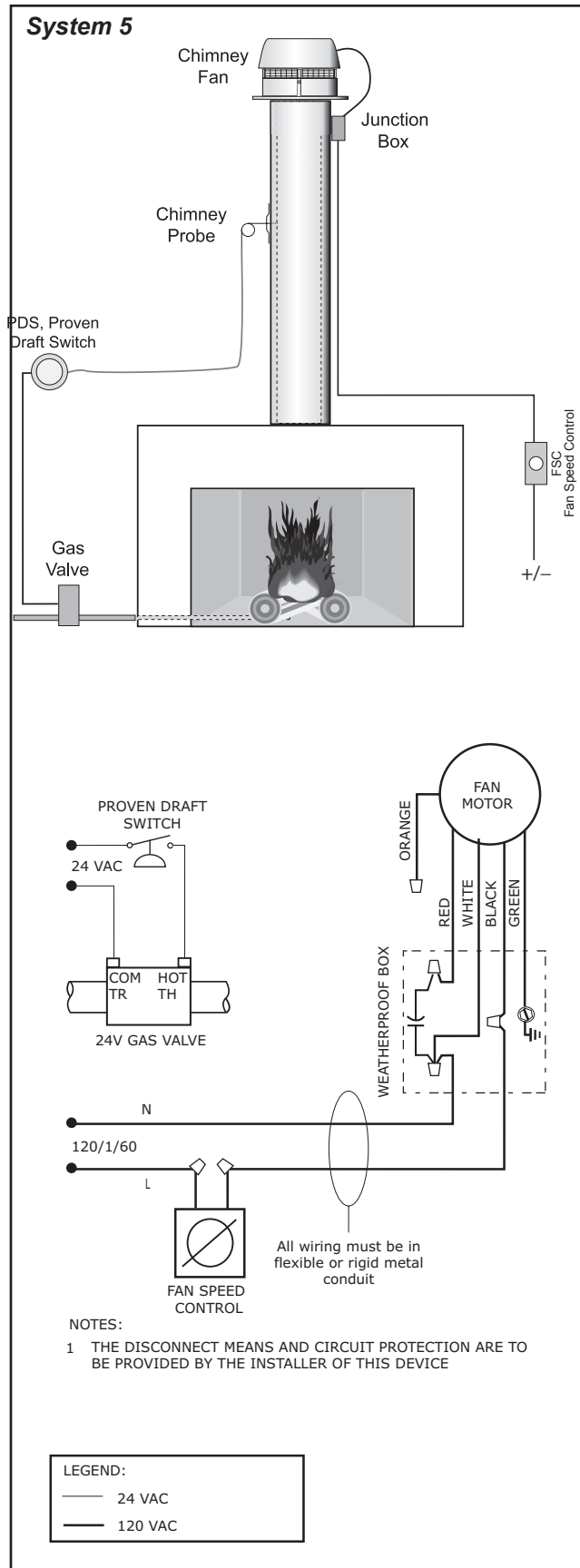



6.6 Mechanical Draft System (automated) for a Gas-Fired Fireplace with a Single Flue with Safety System per NFPA54/IFGC

Application

This is the most automated type of installation for a gas fireplace application. The ADC100 control monitors both operation and the safety system. No adjustments are necessary after the system is installed and commissioned. The ADC100 does not have to be visible and can be installed in the attic.

Proven Draft Switch is part of ADC100 control.

Sequence of Operation

1. During commissioning, the fan speed is set using the potentiometer located on the ADC100 control board.
2. When the gas igniter is activated, the fan speed increases. Once the proven draft switch closes, the fan returns to the speed setting of the potentiometer and the ADC100 releases the gas valve.
3. If proper draft is not maintained, the ADC100 will increase fan speed gradually until the PDS closes. If the PDS has not closed 10 seconds after the fan reaches 100% speed, the ADC100 will shut off the gas valve and go into alarm mode. If the PDS closes while in alarm mode, the fan will resume the original speed setting.
4. Once the fireplace is turned off, the fan will continue to operate for a set post-purge time (adjustable between 0-10 minutes) to remove any remaining products of combustion before shutting down.
5. In case of a mechanical or electrical failure the ADC100 will shut off the gas valve.

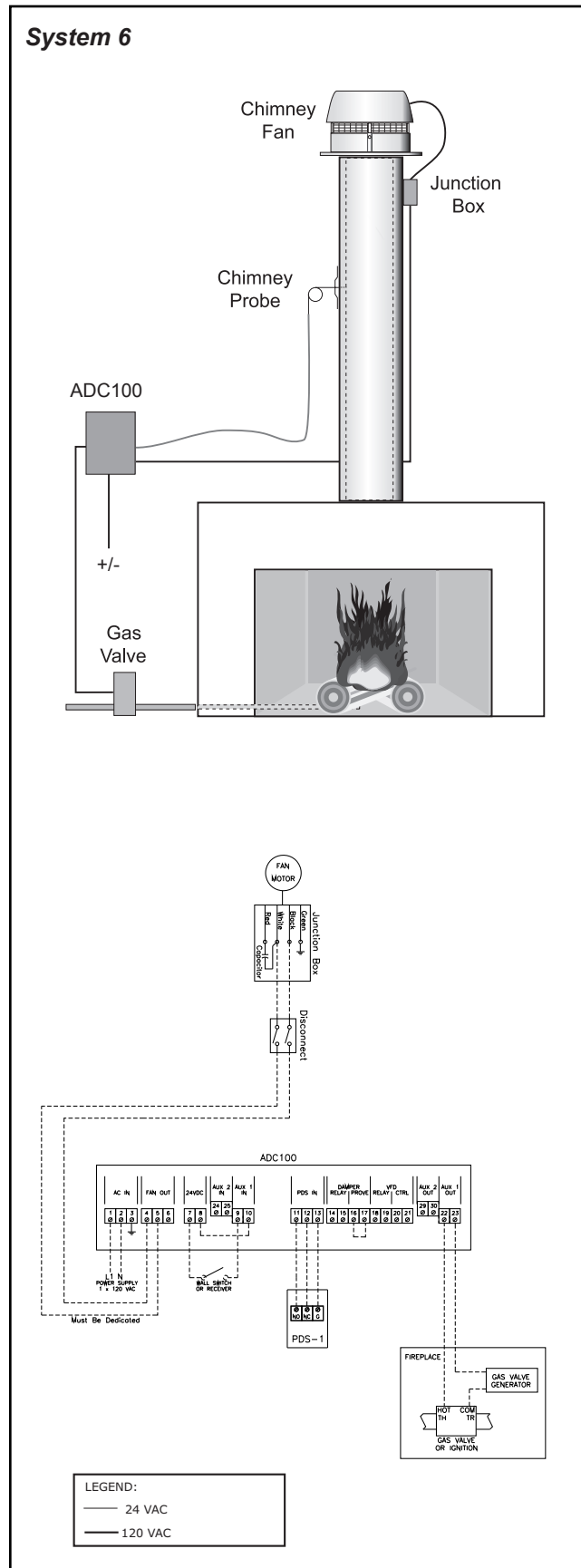

6.7 Mechanical Draft System for a Gas-fired Fireplace with multiple flues with Safety System per NFPA54/IFGC

Application

This is used in the same situations as System 5, but where multiple fans are required to handle the exhaust volume. It is a typical installation for large fireplaces where a single flue cannot handle the amount of exhaust gases generated.

This is a simple form of installation when used with a gas-fired fireplace. The set-up can be used with virtually any type of gas-fired heating appliance.

*For one fan serving two flues please refer to section 6.5 as the wiring diagram is identical. A special plenum box may be required.

Sequence of Operation

1. Turn the fan speed control on by turning the knob clockwise. A “click” indicates the control is turned on. Adjust the knob to the desired speed.
2. Start the fire by pushing the igniter or other means used to start the fire.
3. Fine-tune the fan speed setting so spillage from the fireplace opening can not be detected. Hot, moist heat rising from the top of the fireplace is an indication of spillage. For better detection, hold a mirror over the fireplace opening
4. In case of mechanical or electrical fan failure, the proven draft switch will disconnect the flow of fuel to the fireplace or the gas logs.
5. Once the proper draft has been established in the chimney, the proven draft switch will close to allow the flow of fuel.
6. When the fan is turned off, the proven draft switch will open and automatically turn off the flow of gas.

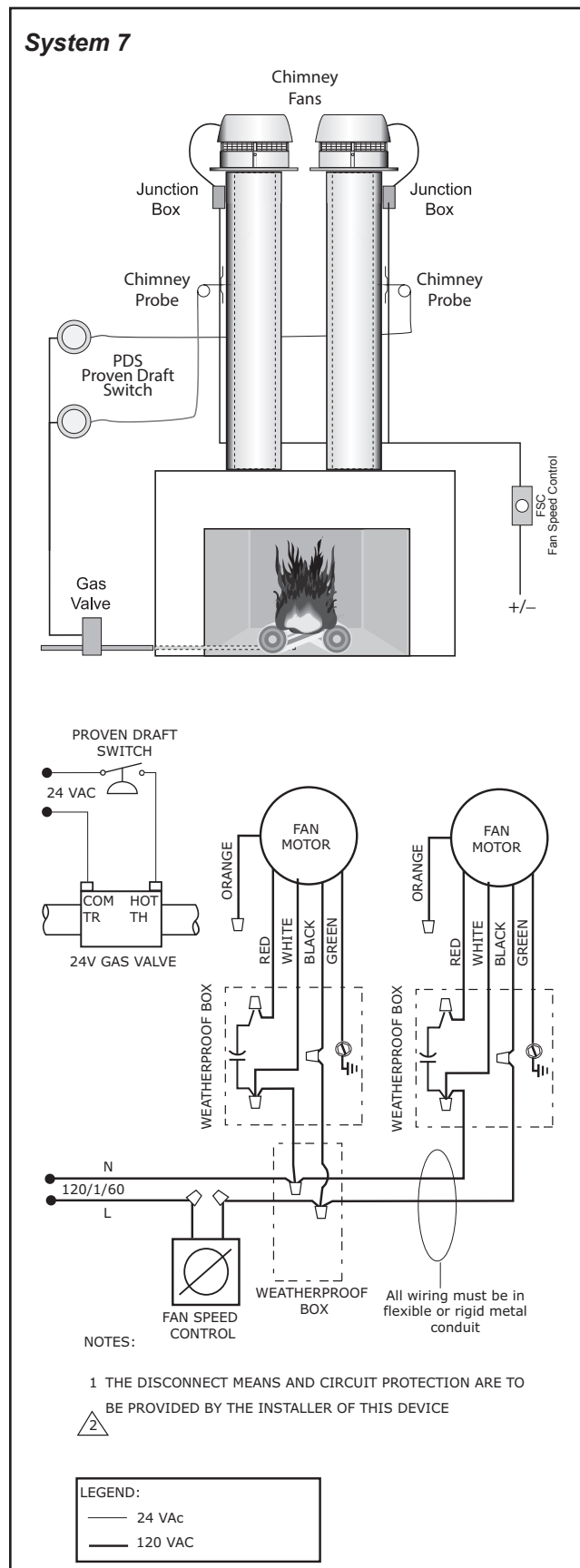



6.8 Mechanical Draft System for a Gas-fired Fireplace with multiple flues and Safety System per NFPA54/IFGC

Application

This is used in the same situations as System 6, but where multiple fans are required to handle the exhaust volume. It is a typical installation for large fireplaces where a single flue cannot handle the amount of exhaust gases generated.

*For one fan serving two flues please refer to section 6.6 as the wiring diagram is identical. A special plenum box may be required.

Sequence of Operation

The fans should be wired in series and connected to the ADC100. Each flue should be connected to a separate proven draft switches and they should also be connected in series.

1. During commissioning, the fan speed is set using the potentiometer located on the ADC100 control board.
2. When the gas igniter is activated, the fan speed increases. Once the proven draft switches close, the fan returns to the speed setting of the potentiometer and the ADC100 releases the gas valve.
3. If proper draft is not maintained, the ADC100 will increase fan speed gradually until the PDS closes. If both proven draft switches have not closed 10 seconds after the fan reaches 100% speed, the ADC100 will shut off the gas valve and go into alarm mode. If the PDS closes while in alarm mode, the fan will resume the original speed setting.
4. Once the fireplace is turned off, the fan will continue to operate for a set post-purge time (adjustable between 0-10 minutes) to remove any remaining products of combustion before shutting down.
5. In case of a mechanical or electrical failure the ADC100 will shut off the gas valve.

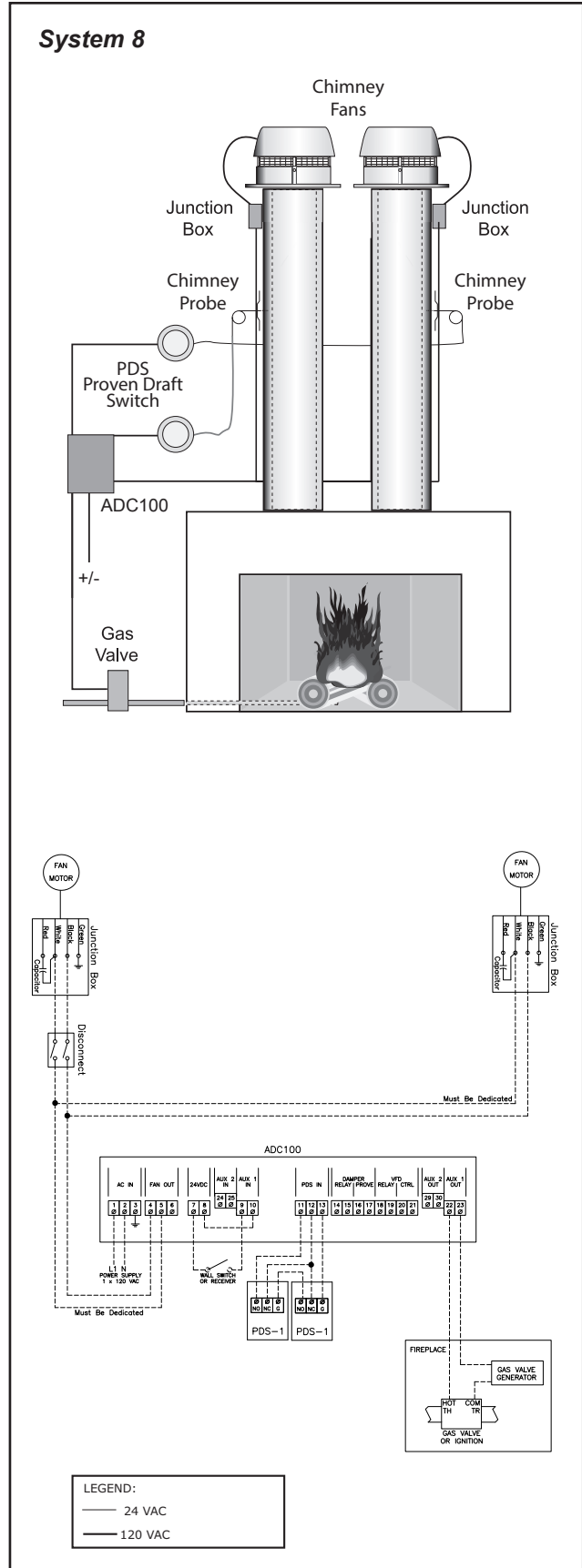

6.9 Mechanical Draft System for a Gas-fired Fireplace with Damper and Safety System per NFPA54/IFGC

Application

This installation shows a combination fireplace and damper system. The ADC100 control monitors fan and damper operation and the safety system. No adjustments are necessary after the system is installed and commissioned. The ADC100 does not have to be visible and can be installed in the attic.

Proven Draft Switch is part of ADC100 control.

Sequence of Operation

1. During commissioning, the fan speed is set using the potentiometer located on the ADC100 control board.
2. When the gas igniter is activated, the fan speed increases and the damper begins to open. Once the damper is fully open and the proven draft switch closes, the fan returns to the speed setting of the potentiometer and the ADC100 releases the gas valve.
3. If proper draft is not maintained, the ADC100 will increase fan speed gradually until the PDS closes. If the PDS has not closed 10 seconds after the fan reaches 100% speed, the ADC100 will shut off the gas valve and go into alarm mode. If the PDS closes while in alarm mode, the fan will resume the original speed setting.
4. Once the fireplace is turned off, the fan will continue to operate for a set post-purge time (adjustable between 0-10 minutes) to remove any remaining products of combustion before shutting down. The damper closes 10 seconds after the fan is shut off.
5. In case of a mechanical or electrical failure the ADC100 will shut off the gas valve.

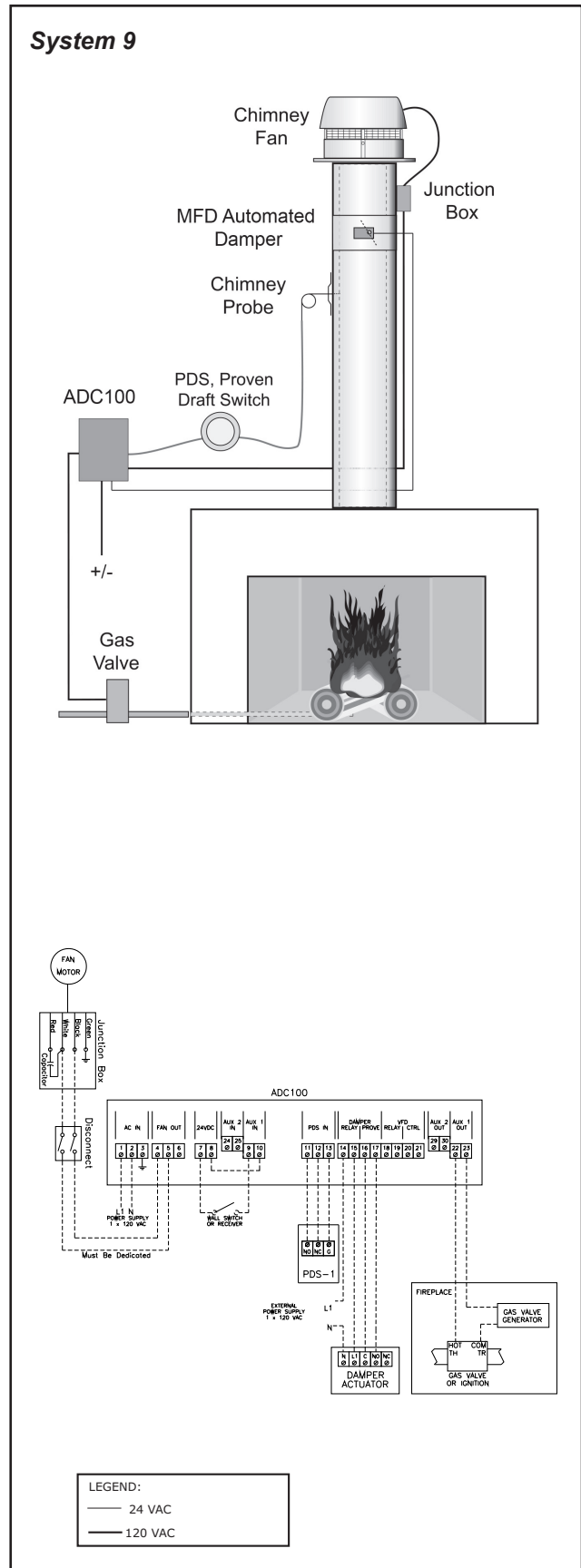

6.10 Mechanical Draft System (automated) for a Gas-Fired Fireplace with Modulating Fan Speed and a Single Flue with Safety System per NFPA54/IFGC

Application

This is the most automated type of installation for a gas fireplace application. The ADC150 control monitors both operation and the safety system. No adjustments are necessary after the system is installed and commissioned. The ADC150 does not have to be visible and can be installed in the attic.

XTP2 Pressure Transducer is part of ADC150 control.

Sequence of Operation

1. During commissioning, the fan speed is set using the potentiometer located on the ADC150 control board.
2. When the gas igniter is activated, the fan speed increases. Once the proven draft switch closes, the fan returns to the speed setting of the potentiometer and the ADC150 releases the gas valve.
3. If proper draft is not maintained, the ADC150 will increase fan speed gradually until the XTP2 closes. If the XTP2 has not closed 10 seconds after the fan reaches 100% speed, the ADC150 will shut off the gas valve and go into alarm mode. If the XTP2 closes while in alarm mode, the fan will resume the original speed setting.
4. Once the fireplace is turned off, the fan will continue to operate for a set post-purge time (adjustable between 0-10 minutes) to remove any remaining products of combustion before shutting down.
5. In case of a mechanical or electrical failure the ADC150 will shut off the gas valve.

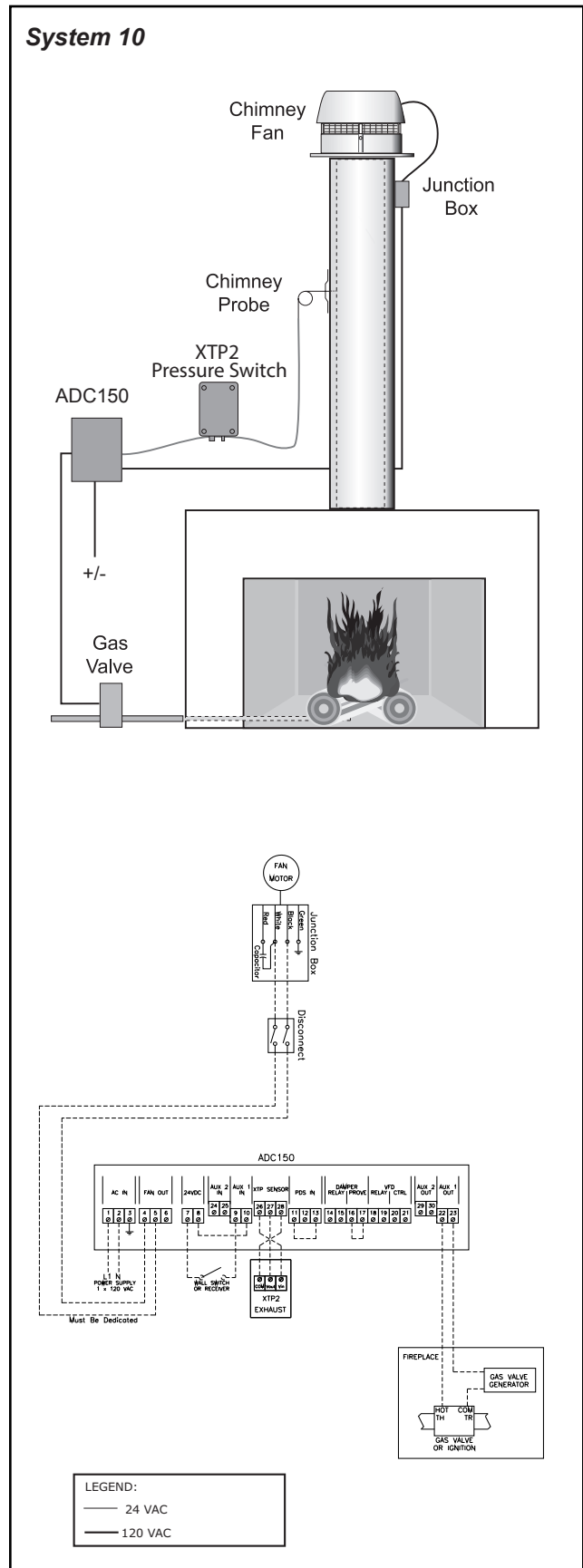

6.11 Mechanical Draft System for a Gas-Fired Fireplace with Modulating Fan Speed, Damper and a Single Flue with Safety System per NFPA54/IFGC

Application

This installation shows a combination fireplace and damper system. The ADC150 control monitors fan and damper operation and the safety system. No adjustments are necessary after the system is installed and commissioned. The ADC150 does not have to be visible and can be installed in the attic.

XTP2 Pressure Transducer is part of ADC150 control.

Sequence of Operation

1. During commissioning, the fan speed is set using the potentiometer located on the ADC150 control board.
2. When the gas igniter is activated, the fan speed increases and the damper begins to open. Once the damper is fully open and the proven draft switch closes, the fan returns to the speed setting of the potentiometer and the ADC150 releases the gas valve.
3. If proper draft is not maintained, the ADC150 will increase fan speed gradually until the XTP2 closes. If the XTP2 has not closed 10 seconds after the fan reaches 100% speed, the ADC150 will shut off the gas valve and go into alarm mode. If the XTP2 closes while in alarm mode, the fan will resume the original speed setting.
4. Once the fireplace is turned off, the fan will continue to operate for a set post-purge time (adjustable between 0-10 minutes) to remove any remaining products of combustion before shutting down. The damper closes 10 seconds after the fan is shut off.
5. In case of a mechanical or electrical failure the ADC150 will shut off the gas valve.

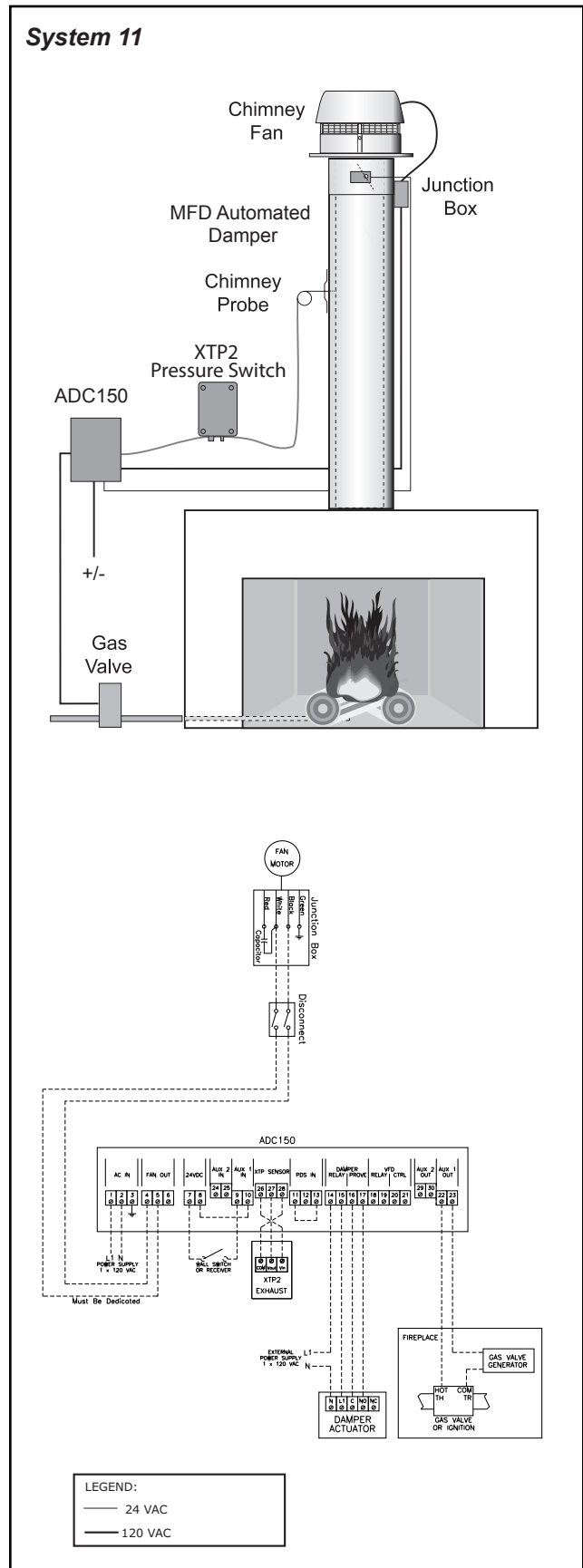

6.12 Mechanical Draft System for a Gas-fired Fireplace with Modulating Fan Speed and multiple flues and Safety System per NFPA54/IFGC

Application

This is used in the same situations as System 6, but where multiple fans are required to handle the exhaust volume. It is a typical installation for large fireplaces where a single flue cannot handle the amount of exhaust gases generated.

*For one fan serving two flues please refer to section 6.6 as the wiring diagram is identical. A special plenum box may be required.

Sequence of Operation

The fans should be wired in series and connected to the ADC150. One flue should be connected to one pressure switch and the other flue should be connected to a separate proven draft switch.

1. During commissioning, the fan speed is set using the potentiometer located on the ADC150 control board.
2. When the gas igniter is activated, the fan speed increases. Once the proven draft switches close, the fan returns to the speed setting of the potentiometer and the ADC150 releases the gas valve.
3. If proper draft is not maintained, the ADC150 will increase fan speed gradually until the XTP2 closes. If both proven draft switches have not closed 10 seconds after the fan reaches 100% speed, the ADC150 will shut off the gas valve and go into alarm mode. If the XTP2 closes while in alarm mode, the fan will resume the original speed setting.
4. Once the fireplace is turned off, the fan will continue to operate for a set post-purge time (adjustable between 0-10 minutes) to remove any remaining products of combustion before shutting down.
5. In case of a mechanical or electrical failure the ADC150 will shut off the gas valve.
6. If two RS16s are used, an EBC12x should be incorporated.

System 12

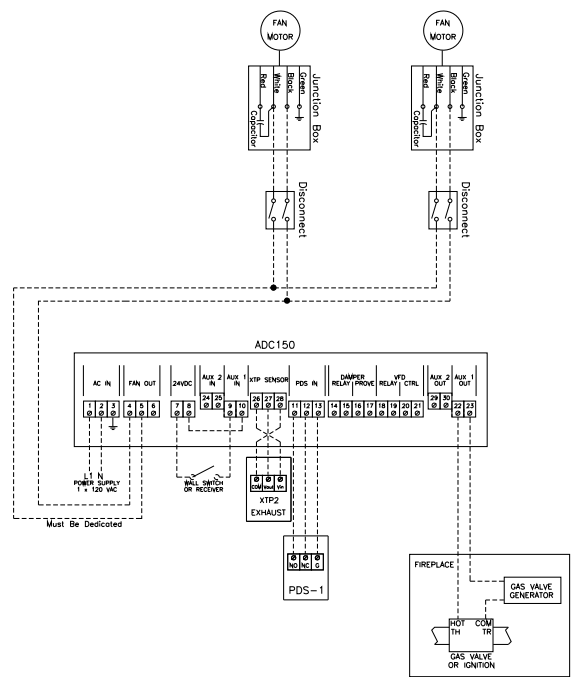
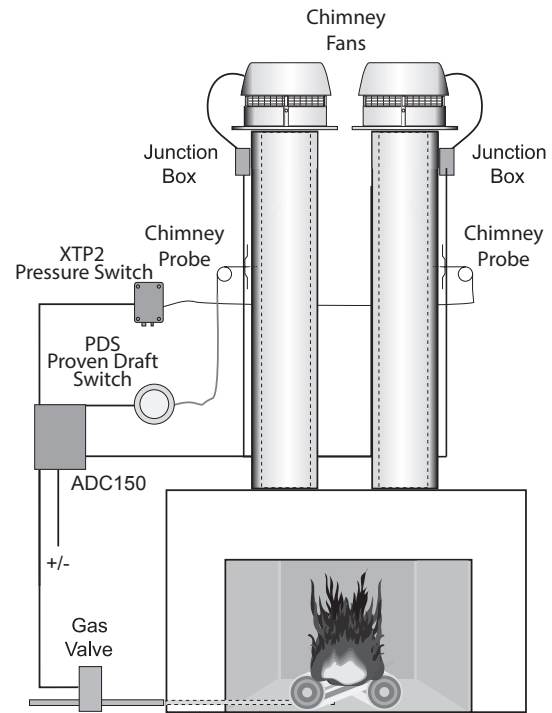

LEGEND:
 — 24 VAC
 — 120 VAC

7. Frequently Asked Questions

Q. Does the fan always have to be on when I have a fire in the fireplace?

A. The motor can only be cooled when the chimney fan is operating, thus the fan should always be on when you have a fire in the fireplace. Otherwise, you may reduce the longevity of the fan. You may, however, run it at a very low speed.

Q. The fireplace spills due to negative pressure in the house. Won't the chimney fan add to the problem?

A. Any exhaust fan will pull air out. However, proper use of the fan speed control assures the chimney fan simply simulates the natural draft required for the fireplace to operate. Thus, the chimney fan will not exhaust more air than a well-functioning fireplace would have done.

*It is important to emphasize that all furnaces, water heaters and other combustion equipment be checked for proper venting before regular use of a chimney fan.

Q. Can the fan be recessed or hidden?

A. Yes, the fan may be recessed or hidden, with chimney pots, copper caps, or cupolas, as long as the fan is allowed to vent properly. ENERVEX recommends a minimum clearance of 1 1/2" on each side of the fan.

Q. Does the chimney fan have to be removed every time I have my chimney cleaned?

A. No, the fan is equipped with hinges, which allows the top of the fan to be tilted. This gives full access to the chimney for cleaning purposes.

Q. Does the fan require its own circuit?

A. No, the fan only draws about 1 to 4 amps (about the same as a standard light bulb), depending on the size, and runs on 110 volts.

Q. Can you run the wire inside the flue?

A. No. However, it may be run inside a chase. Otherwise it will have to be run on the outside of the chimney.

Q. What happens when you have a fire in the fireplace and a power failure occurs?

A. Obviously, the fan will stop working, and you may experience the same problems with smoke or draft that caused you to put the fan on to begin with. However – a power failure will cause all other fans in the house to stop running as well, which may increase the natural draft in the chimney. The fan itself offers very little resistance to the flow.

Q. What if the chimney has a constant down-draft and odor when not in use?

A. Leave the fan running continuously at a very low setting.

Q. Is the fan noisy?

A. The fan is equipped with a very quiet motor, and is installed outside and at the end of the chimney. Noise is usually not an issue unless the fan is installed incorrectly or if the flue is extremely narrow or short.

Q. How involved is the installation?

A. Installations vary from house to house, but typically a fan can be installed and wired in just a few hours. No major reconstruction is needed.

Q. Can the fan be installed on a pre-fabricated chimney?

A. Yes, the fan can be installed on a pre-fabricated metal chimney. An adapter is used to fit the fan onto the size and type of metal chimney in use.

Q. What about the appearance of the fan?

A. The fan is low-profile and a flat charcoal grey in color. In most cases, the fan is barely noticeable from the ground. As discussed in a previous FAQ, the fan can be disguised by a cap or chimney pot. The fan may be painted with a high-temperature paint to match the house if so desired.

Q. How much energy does the fan use?

A. The chimney fan consumes a minimal amount of energy - about as much as a standard light bulb - so you do not have to worry about high energy bills or an overloaded circuit breaker.

Q. What happens to the fan in very windy weather?

A. Nothing. The fan will certainly stay in place on the chimney and is strong enough to counter any gusts while operating.

Q. Do you guarantee it will work?

A. Yes. We offer a six month unconditional money-back guarantee should the fan not meet your expectations. Furthermore, each fan comes with a two year factory warranty and ten year corrosion warranty.



Appendix A: Design Theory

Fireplaces with natural draft chimneys follow the same gravity fluid law as gas vents and thermal flow ventilation systems.

To a certain degree, mass flow of hot flue gases through a vertical pipe is a function of the heat release, the chimney area, height, and the flow resistance (system pressure loss coefficient).

According to ASHRAE, standard sizing of chimneys must include an estimate of the flue gas volume and the available draft. Available draft is the difference between the natural draft and the system pressure loss. The available draft must be able to overcome the system pressure loss for the system to work.

There are limitations to this approach. A lot can be determined and explained via calculations, but some factors must be determined by using common sense and experience. The location of a building, the presence of cross winds, eddies etc. are examples of such factors. The factors can be expressed as pressure losses, but it is not easy to put a value to them.

The flue gas volume depends on the fuel burned and the amount of air used for the combustion. The general method used to determine the flue gas volume is to base the calculation on the air requirements of the combustion.

The air requirement is found by determining the area of the air inlet and multiplying it with the frontal inlet velocity. As the air expands when it is warmed up in the fire, the actual flow in the chimney depends on the temperature in the chimney.

A 300° F mean gas temperature rise above ambient (usually 60°F) is used as a guideline, and with this temperature rise, the air will expand by almost 60%. Airflow at 60°F is usually expressed as “standard cubic feet per minute” or SCFM. If the air is heated and expansion is accounted for it is usually expressed as “actual cubic feet per minute” or ACFM.

The following examples will show how the flue gas volume can be determined for different applications.

Estimating Flow

The combustion air requirements can be determined using this formula:

$$Q_t = \frac{q \times A_{\text{inlet}} \times V_{\text{inlet}}}{144}$$

Q_t = Flow at t °s (CFM, or cubic feet per minute)

A_{inlet} = Area of opening (square inches)

V_{inlet} = Frontal inlet velocity (FPM, or feet per minute)

q = density expansion factor (unitless)

One-sided fireplaces for solid fuel

In a one-sided fireplace a total front velocity of 36-48 FPM with a mean chimney temperature of min. 300°F should provide a good combustion and a well-working fireplace.

Example: Fireplace height is 24”, width is 36” and the frontal velocity is estimated at 48 FPM. The flow into the fireplace is:

$$Q_{60} = \frac{24 \times 36 \times 48 \text{ CFM}}{144} = 288 \text{ SCFM}$$

The density expansion factor is 1.6 at a 300°F temperature rise, so the flue gas volume is:

$$Q_{300} = 288 \text{ SCFM} \times 1.6 = 460 \text{ ACFM}$$

In other words, a wood-fired fireplace with a 2'x3' opening produces 460 ACFM of flue gas at an average flue gas temperature of 300°F, while it only consumes 288 SCFM from the room.

One-sided fireplaces for gas

In a one-sided fireplace a total front velocity of 18-36 FPM with a mean chimney temperature of min. 200°F should provide a good combustion and a well-working fireplace.

Example: Fireplace height is 24”, width is 36” and the frontal velocity is estimated at 36 FPM. The flow into the fireplace is:

$$Q_{60} = \frac{24 \times 36 \times 36 \text{ FPM}}{144} = 216 \text{ SCFM}$$

The density expansion factor is 1.4 at a 200°F temperature rise, so the flue gas volume is:

$$Q_{200} = 216 \text{ SCFM} \times 1.4 = 302 \text{ ACFM}$$

In other words, a gas-fired fireplace with a 2'x3' opening produces 302 ACFM of flue gas at an average flue gas temperature of 200°F, while it only consumes 216 SCFM from the room.

Open fireplaces without a smoke chamber

If the fireplace does not have a smoke chamber, or if the smoke chamber is very small, it is wise to use a higher frontal inlet velocity – preferably in the range of 36-48 FPM.

Freestanding fireplaces

This type of fireplace requires a high frontal inlet velocity in order to capture and contain the products of combustion. For design purposes it is recommended to use a velocity of 36-48 FPM. This is in line with the code requirements for commercial kitchen hoods.

Stoves and fireplace inserts

Stoves are different from open fireplaces due to the fact that they have a small inlet for the combustion air. However, the worst-case scenario occurs when the door is open, so this is the situation the sizing should be based on.

Again, use the airflow formula with a recommended frontal inlet velocity of 36-48 FPM.

This design method is also used for a fireplace insert

$$Q_{300} = \frac{A_{\text{inlet}} \times V_{\text{inlet}} \times 1.6}{144}$$

The flow is determined by using the fireplace opening with the doors opened.

Residential wood-fired pizza ovens

This type of appliance is both an oven and a firebox. The door opening serves as an air inlet as well as the flue outlet.

Temperatures can reach 500-600°F, but the flue gas temperature is much lower due to the design of the smoke chamber. The smoke chamber is just a small hood that leads into the flue.

For design purposes it is recommended to use a frontal inlet velocity of 36-48 FPM. The formula for calculating the airflow is:

Estimating Flow Resistance

$$Q_{300} = \frac{A \times B \times V_{\text{inlet}} \times 1.6}{144}$$

A = height of door opening

B = width of door opening

The total flow resistance in a vent system that moves air is normally referred to as “total static pressure loss”. The formula used to determine the static pressure loss in a system is:

$$P_s = .003 \times d_m \times V_{\text{pipe}}^2 \times \Sigma k$$
$$= .003 \times d_m \times (Q_t / A_{\text{pipe}})^2 \times \Sigma k$$

d_m = gas density (lb/ft³)

V_{pipe} = system gas velocity at mean condition (ft/s).
Can also be expressed as flue gas volume / flue area)

A_{pipe} = area of flue (square inches)

Σk = sum of all resistance factors

There are several factors creating resistance in fireplace chimney system:

- the flue
- flue components and fittings

- transition from firebox to flue

In addition there are “external” factors influencing the resistance:

- internal building pressure
- external building pressure
- wind patterns

When trying to determine the total resistance in a chimney system, resistance factors, or k-values, are used to ease calculations. K-values are dimensionless.

Flue pipe resistance

As in any pipe material, the roughness of the surface influences the flow resistance - the rougher the surface, the more resistance. Roughness of a pipe surface is normally expressed as a Reynold’s number, but for all practical purposes these can be converted into k-values that are easier to work with.

ASHRAE has set a range of friction factors that chimney and stack manufacturers use for the calculation of k-values for different types of chimneys and vents:

<u>Vent type</u>	<u>Friction factor, F</u>
Class A chimney	0.22
Gas Vent (B-vent)	0.25
Single wall steel	0.32
Refractory liners	0.34
Clay tile liners	0.38-0.42
Corrugated liners	0.50

The k-value of a chimney can be determined with this formula:

$$K_L = F \times L / D_i$$

L = Length of entire chimney system (ft)

D_i = Diameter of chimney (inches)

F = Friction Factor

Example: An 8” single steel wall system with a total length of 25’ has a k-value of:

$$K_L = .32 \times 25 / 8 = 1.0$$

Resistance inside firebox

Resistance can be found in the transition between the firebox and the chimney. The transition can be considered a converging tapered entry. Allow for a k-value of min. 2, if the inlet is smooth – more if it’s rough.



Component resistance

ASHRAE has set up a range of k-values for different types of components in a chimney system. Chimney and stack manufacturers have set specific values for their own products. A list of component k-values can be found in Appendix C.

Other resistance

Resistance from negative building pressure, external building pressures, eddies etc. must also be taken into consideration. This could actually be measured by using a pressure gauge in the fireplace chimney before starting a fire. It is not that unusual to see a negative pressure of 0.05-0.1"WC for problem fireplaces.

Estimating natural draft

The theoretical draft of a gravity chimney or vent is the difference in weight (mass) between a given column of warm flue gas and an equal column of

$$D_t = .2554 \times B \times H \times (1/T_o - 1/T_m)$$

D_t = Theoretical draft ("WC)

B = Local barometric pressure (inHg)

H = Height of chimney (feet)

T_o = Absolute ambient temperature(°F) – Ambient(°F) + 460 (°R)

T_m = Absolute mean flue gas temperature(°F) – Mean flue gas(°F) + 460 (°R)

colder ambient air. The theoretical can be derived from the following formula:

The formula indicates that the draft increases with the height. However, as the height increases the mean flue gas temperature decreases, so adding height to create more draft only works up to a certain height.

Example: With a barometric pressure of 29.92 inHg, a 25' chimney, 70°F ambient temperature and a mean flue gas temperature of 250°F, the theoretical draft will be:

$$D_t = .2554 \times 29.92 \times 25 \times (1/530 - 1/710) = 0.091 \text{ "WC}$$

According to the formula a chimney without draft does not exist.

Estimating available draft

To derive the available draft (D_a) for a chimney system, the static pressure loss is deducted from the theoretical draft:

$$D_a = -D_t + P_s$$

Notice that draft is always negative, while static pressure is always positive.

Example:

Theoretical draft, D_t	- 0.138 "WC
Static Pressure Loss, P_s	+ 0.100 "WC
Available draft, D_a	<u>- 0.038 "WC</u>

Analyzing a fireplace venting system

The following is an example on how to analyze and estimate fireplace systems. The data is as follows:

One-sided fireplace for wood: 24" x 36"

Ambient temperature = 60°F

Mean chimney temperature = 300°F

Chimney = single wall steel chimney

Flue size = 8"

Chimney height = 25'

Off-sets = one 30° off-set (= 2x30° elbows)

d_m = 0.075 lbs/ft³ @ 60°F

= 0.047 lbs/ft³ @ 300°F

1. Determine flow

$$Q_t = q \times A_{inlet} \times V_{inlet} / 144$$

$$= \frac{1.6 \times 24 \times 36 \times 48}{144} = 460 \text{ ACFM}$$

* V_{in} = see table in Chapter 5.1

2. Determine k-values

Pipe:

$$K_L = F \times L / D_i = 0.32 \times 25 / 8 = 1.0$$

Components:

$$2 \times 30^\circ \text{ elbows} = 2 \times 0.15 = 0.30$$

$$\text{Inlet from firebox} = 2.00$$

$$\text{Total k-value} = 2.30$$

$$\Sigma k = 1.0 + 2.30 = 3.3$$

3. Determine system pressure loss

$$P_s = 0.003 \times d_m \times (Q_t / A_{pipe})^2 \times \Sigma k$$

$$= 0.003 \times 0.047 \times (460 / 50)^2 \times 3.3$$

$$= 0.039 \text{ "WC}$$

4. Determine natural draft

$$D_t = 0.2554 \times B \times H \times (1 / T_o - 1 / T_m)$$

$$= 0.2554 \times 29.92 \times 25 \times (1/530 - 1/710)$$

$$= 0.091 \text{ "WC}$$

5. Determine available draft

$$\begin{aligned}D_a &= -D_t + P_s \\ &= -0.091 + 0.039 \\ &= -0.052\text{''WC}\end{aligned}$$

The available draft is negative so the system should work.

If the draft is positive, adjustments can be made to the system to make it negative. There are two ways to solve this problem: increase the chimney height or increase the chimney diameter.

Analyzing other factors

If the fireplace and chimney seem to be sized correctly, but there is a smoke problem, other information may be needed.

A depressurized building will negatively affect the draft situation. If the negative pressure is found to be 0.1''WC, the chimney would have to be able to overcome this as well and the draft calculation would look like this:

$$D_a = -0.052\text{''WC} + 0.1\text{''WC} = +0.048\text{''WC}$$

In other words, the negative building pressure easily overcomes the draft and would make the system back draft.

Appendix B: Conversion table from rectangular to round flues

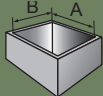

		Equivalent Diameter (ID) (inch)																
		4	5	6	7	8	9	10	11	12	13	14	15	16	17	18	19	20
4	B	4	4	5	5	5	6	6	6	6	6	6	6	6	7	7	7	
5	B	4	5	5	6	6	6	7	7	7	7	7	8	8	8	8	8	
6	B	5	5	6	6	7	7	8	8	8	8	9	9	9	9	9	9	
7	B	5	6	6	7	7	8	8	9	9	9	9	10	10	10	10	10	
8	B	5	6	7	7	8	8	9	9	10	10	10	10	11	11	11	11	
9	B	6	6	7	8	8	9	9	10	10	11	11	11	12	12	12	12	
10	B	6	7	8	8	9	9	10	10	11	11	12	12	12	13	13	13	
11	B	6	7	8	9	9	10	10	11	11	12	12	13	13	13	14	14	
12	B	6	7	8	9	10	10	11	11	12	12	13	13	14	14	14	15	
13	B	6	7	8	9	10	11	11	12	12	13	13	14	14	15	15	16	
14	B	6	7	8	9	10	11	12	12	13	13	14	14	15	15	16	16	
15	B	6	8	9	10	10	11	12	13	13	14	14	15	15	16	16	17	
16	B	6	8	9	10	11	12	12	13	14	14	15	15	16	16	17	18	
17	B	6	8	9	10	11	12	13	13	14	15	15	16	16	17	17	18	
18	B	7	8	9	10	11	12	13	14	14	15	16	16	17	17	18	19	
19	B	7	8	9	10	11	12	13	14	15	15	16	17	17	18	18	19	
20	B	7	8	9	10	11	12	13	14	15	16	16	17	18	18	19	20	

Appendix C: Resistance Factors

	Gas Vent	Pressure Stack	Clay Tile Liner	Poured/Cast Liner	Single Wall Steel	Corrugated Steel/Alum.
Pipe Coefficient	0.25	0.22	0.38	0.34	0.32	0.50
30° Elbow	0.15	0.12	0.18	0.18	0.15	0.30
45° Elbow	0.25	0.15	0.28	0.28	0.25	0.50
90° Elbow	0.75	0.30	0.90	0.90	0.75	1.5
Tee or 90° Connector	1.25	1.25	1.25	1.25	1.25	1.75
90° WYE	0.60	0.60	0.60	0.60	1.60	0.60
Barometric Damper	0.50	0.50	0.50	0.50	0.50	0.50
Round to Square Transition	0.50	0.50	0.50	0.50	0.50	0.50
Low Resistance Cap (listed)	0.50	0.50	0.50	0.50	0.50	0.50
Standard Cap (not listed)	1.00	1.00	1.00	1.00	1.00	1.00
Bird Screen	0.50	0.50	0.50	0.50	0.50	0.50
Tapered Reducer	From d_1 to d_2 : $1 - (d_2 / d_1)^4$					

Sources and References:

- 1) 2008 ASHRAE Handbook, HVAC Systems and Equipment, 2000
- 2) International Fuel Gas Code, International Code Council, 2009 Edition
- 3) NFPA 211 Standard for Chimneys, Fireplaces, Vents, and Solid Fuel-Burning Appliances, 2010 Edition.
- 4) 2009 National Fuel Gas Code (NFPA54/ANSI Z223.1), 2006 Edition
- 5) 2009 International Mechanical Code, International Code Council, 2006 Edition.
- 6) UL (1996). Standard for Gas Vents. UL441, Northbrook, IL: Underwriters Laboratories, Inc.
- 7) UL (2001). Standard for Chimneys, Factory-Built, Residential Type and Building Heating Appliance. Northbrook, IL: Underwriters Laboratories, Inc.
- 8) Metalbestos Sizing Handbook, Chimney & Gas Vent, Selkirk Metalbestos, 1992
- 9) Sizing Handbook, Simpson-Duravent (no publishing year provided)
- 10) Article: Downsizing of Fireplace Flues by Charlie Page, Protech Systems, Inc., Sweeping, September 1993.
- 11) Article: Backdrafting Woes by Sebastian Moffat, Progressive Builder, December 1986
- 12) Article: Indoor Air Pressure in Tightly Built Homes: An Important Consideration by Roger A. Peterson, Cold Climate Housing Newsletter, June 1988.
- 13) Article: Indoor Air Quality, Part II by Paul Stegmeir, Hearth & Home, April 1994
- 14) Article: Dealing with Indoor Quality by Paul Stegmeir, Hearth & Home, February 1994
- 15) Fine Homebuilding, April/May 2004



The products

RS Chimney Fan

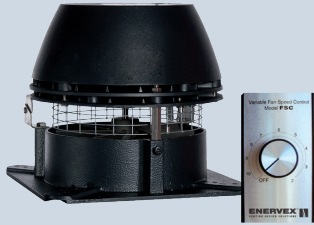

Made of high quality, recycled cast aluminum, RS Chimney Fans keep the perfect draft for a long time. The fan features a quiet, enclosed pre-lubricated motor and is recommended to be used with gas or oil fireplaces, stoves, ovens, furnaces, water heaters, BBQs, and pizza ovens.

FSC variable Fan Speed Control comes standard with the fan.

RSHT Chimney Fan



The RSHT Chimney Fan is a high temperature exhaust fan used to maintain proper draft in a solid fuel chimney or stack system. The fan assures a negative pressure is maintained in the entire chimney or stack system. Typical uses include venting of fireplaces, BBQ's, pizza ovens and stoves.

FSC variable Fan Speed Control comes standard with the fan.

MFD Mechanical Fireplace Damper



The low profile Mechanical Fireplace Damper (MFD) is an accessory to be used in conjunction with an ADC 100 and ADC 150 control and a chimney fan as part of the EcoDamper and IntelliDraft System. This damper prevents excess heat from escaping through the chimney when the fireplace is not in use and eliminates the need for glass doors.

MFD-S Manual Fireplace Damper

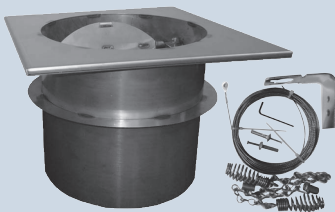

The MFD-S Manual Fireplace Damper for solid fuel prevents excess heat from escaping through the chimney when the fireplace is not in use, and to prevent downdrafts. The MFD-S is designed for chimney top installations and is for use with solid fuel fireplaces and appliances.

ADC100 Draft Control



The ADC100 Control, for gas appliances, has pre- and post-purge features, an integrated damper relay and a draft switch that shuts the appliance off when there isn't enough draft, protecting your family from dangerous flue-gasses.



ADC150 Draft Control



The ADC150 Control, for gas appliances, monitors the draft and will maintain the proper draft set-point by modulating the chimney fan speed whenever needed. When the user turns the fireplace or appliance off, the control leaves the damper open until all residual combustion products have been exhausted.

EFC 211 Control



Use the EFC211 control with wood-fired heating appliances to control the proper speed of the chimney fan. The EFC211 fan control features an audible and visual alarm.

PDS1 Proven Draft Switch



Use the PDS1 Proven Draft Switch to provide protection from insufficient draft. When there is an unsafe draft, the switch shuts down the gas-fired appliance or fireplace.

XTP2 Pressure Sensor



The XTP2 is a pressure transducer that monitors the pressure at an appliance outlet, in an exhaust duct or in a room. The ADC 150 control box communicates with the XTP2, and the readings are used to determine whether to increase or decrease the fan speed.

FSC Fan Speed Control



ENERVEX Fan Speed Control FSC is used in conjunction with all single-phased chimney fans. The fan speed control is specially engineered to provide variable speed control of split capacitor motors. The control is accomplished by reducing the line voltage to the motor thereby using only the energy required to maintain the desired volume of air flow (fan speed).



ENERVEX Inc.
1200 Northmeadow Pkwy.
Suite 180
Roswell, GA 30076
USA

P: 770.587.3238
F: 770.587.4731
T: 800.255.2923
info@energex.com
www.chimneyfans.com

ENERVEX[®] 
VENTING DESIGN SOLUTIONS